

ROWLAND WATER DISTRICT

3021 South Fullerton Road
Rowland Heights, CA 91748
(562) 697-1726

RWD BOARD VISION

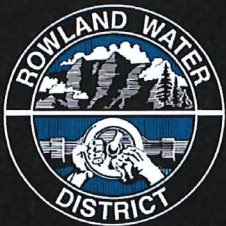

Our Mission:

*"Bound by our core values -- Accountability, Communication and Teamwork -- we are committed to providing the highest level of service to our customers --
DEDICATED-RELIABLE-OUTSTANDING-PROFESSIONAL SERVICE"*

**Board of Directors Regular Meeting
October 11, 2016
6:00 p.m.**



AGENDA
Regular Meeting of the Board of Directors
October 11, 2016
6:00 PM

CALL TO ORDER

PLEDGE OF ALLEGIANCE

ROLL CALL OF DIRECTORS

Szu Pei Lu-Yang, President
Robert W. Lewis, Vice President
Anthony J. Lima
John Bellah
Teresa P. Rios

ADDITION(S) TO THE AGENDA

PUBLIC COMMENT ON NON-AGENDA ITEMS

Any member of the public wishing to address the Board of Directors regarding items not on the Agenda within the subject matter jurisdiction of the Board should do so at this time. With respect to items on the agenda, the Board will receive public comments at the time the item is opened for discussion, prior to any vote or other Board action. A three-minute time limit on remarks is requested.

Any person may make a request for a disability-related modification or accommodation needed for that person to be able to participate in the public meeting by telephoning Rose Perea, Secretary to the Board at (562) 697-1726, or writing to Rowland Water District, at 3021 Fullerton Road, Rowland Heights, CA 91748. Requests must specify the nature of the disability and the type of accommodation requested. A telephone number or other contact information should be included, so that District staff may discuss appropriate arrangements. Anyone requesting a disability-related accommodation should make the request with adequate time prior to the meeting in order for the District to provide the requested accommodation.

Any member of the public wishing to participate in the meeting, who requires a translator to understand or communicate in English, should arrange to bring a translator with them to the meeting.

Materials related to an item on this Agenda submitted after distribution of the Agenda packet are available for public review at the District office, located at 3021 Fullerton Road, Rowland Heights, CA 91748.

- 2.3 Review and Approve Interest in Real Property Conveyed by the Easement Deed from KRAUZ PUENTE THREE, LLC, a Delaware Limited Liability Company (Grantor) to Rowland Water District (Grantee).
Address: 1542 S. Azusa Avenue, Industry, CA 91748, APN: 8265-004-114.
Recommendation: The Board of Directors approve acceptance of the Easement Deed.**
- 2.4 Review and Approve Quitclaim Deed from Rowland Water District (Grantor) to KRAUZ PUENTE THREE, LLC, a Delaware Limited Liability Company (Grantee).
Address: 1542 S. Azusa Avenue, Industry, CA 91748, APN: 8265-004-045.
Recommendation: The Board of Directors authorize Tom Coleman, General Manager, to execute the Quitclaim Deed.**
- 2.5 Discuss “Communication with Those Charged with Governance” letter From White Nelson Diehl Evans, LLP
*For information purposes only.***
- 2.6 Public Relations (Rose Perea)**
- **Communications Outreach (CV Strategies)**
 - **Education Update**
- For information purposes only.*
- 2.7 Discussion of Upcoming Conferences, Workshops, or Events (Including Items that May Have Arisen after the Posting of the Agenda)**
- None

Tab 3 LEGISLATIVE INFORMATION

- 3.1 Updates on Legislative Issues**
Intentionally left blank.

Tab 4 REVIEW OF CORRESPONDENCE

Intentionally left blank.

Tab 5 COMMITTEE REPORTS

- 5.1 Three Valleys Municipal Water District (Directors Lu-Yang/Lima)**
- Agenda Regular Board Meeting held September 21, 2016
 - Action Line Regular Board Meeting held September 21, 2016
- 5.2 Joint Powers Insurance Authority (Director Lewis/Mr. Coleman)**
- Training and Risk Assessment Letter from ACWA/JPIA

There are no tabs for the remainder of the meeting.

- 5.3 Association of California Water Agencies** (Directors Lewis/Bellah)
- 5.4 Puente Basin Water Agency** (Directors Lima/Lewis)
- 5.5 Project Ad-Hoc Committee** (Directors Lima/Lu-Yang)
- 5.6 Regional Chamber of Commerce-Government Affairs Committee**
(Directors Lewis/Bellah)
- 5.7 PWR Joint Water Line Commission** (Directors Lima/Rios)
- 5.8 Sheriff's Community Advisory Council** (Directors Lu-Yang/Rios)

Tab 6 OTHER REPORTS, INFORMATION ITEMS AND COMMENTS

- 6.1 Finance Report** (Mr. Henry)
- 6.2 Operations Report** (Mr. Warren)
- 6.3 Personnel Report** (Mr. Coleman)

Tab 7 ATTORNEY'S REPORT (Mr. Joseph Byrne)

Directors' and General Manager's Comments

Future Agenda Items

Late Business

No action shall be taken on any items not appearing on the posted agenda, except upon a determination by a majority of the Board that an emergency situation exists, or that the need to take action arose after the posting of the agenda.

ADJOURNMENT

President SZU PEI LU-YANG, Presiding

Tab

1.1



Minutes of the Regular Meeting
of the Board of Directors of the Rowland Water District
September 13, 2016 - 6:00 p.m.
Location: District Office

PLEDGE OF ALLEGIANCE

ROLL CALL OF DIRECTORS

President Szu Pei Lu-Yang
Vice President Robert W. Lewis
Director Anthony J. Lima
Director John Bellah
Director Teresa P. Rios

ABSENT:

None.

OTHERS PRESENT:

Ruben Duran, Legal Counsel, Best Best & Krieger
Erin LaCombe Gilhuly, CV Strategies
Joe Ruzicka, Three Valleys Municipal Water District
Dan Horan, Three Valleys Municipal Water District
Kirk Howie, Three Valleys Municipal Water District
Teri Malkin, Resident

ROWLAND WATER DISTRICT STAFF

Tom Coleman, General Manager
Rose Perea, Director of Administrative Services
Sean Henry, Finance Officer

ADDITION(S) TO THE AGENDA

None.

PUBLIC COMMENT ON NON-AGENDA ITEMS

None.

Tab 1 - CONSENT CALENDAR

Upon motion by Director Lima, seconded by Director Lewis, the Consent Calendar was unanimously approved as presented.

Ayes: Directors Lu-Yang, Bellah, Lima, Lewis and Rios
Noes: None
Abstain: None
Absent: None

The approval of the Consent Calendar as modified included:

1.1

Approval of the Minutes of Regular Board Meeting Held on August 9, 2016

1.2

Approval of the Minutes of Special Board Meeting Held on August 30, 2016

1.3

Demands on General Fund Account for July 2016

1.4

Investment Report for July 2016

1.5

Water Purchases for July 2016

Next Special Board Meeting September 27, 2016, 5:00 p.m.
Next Regular Board Meeting October 11, 2016, 6:00 p.m.

Tab 2 - ACTION ITEMS

2.1

Approve Directors' Meeting Reimbursements for July 2016

A clerical error occurred on Director Lewis' report. The adjustment will be made on next month's report. Upon motion by Director Lima, seconded by Director Rios, the Directors' Meeting Reimbursement Report was unanimously approved as amended.

Ayes: Directors Lu-Yang, Bellah, Lima, Lewis and Rios
Noes: None
Abstain: None
Absent: None

2.2

Review Nelson Diehl Evans LLP Audit Engagement Letter for the Year Ended June 30, 2016

This item was presented for information purposes only.

2.3

Consider Amending District “Ethics Guidelines for Directors” to Add the Attendance at Walnut Valley Water District Board Meetings by a District Representative, or Alternate, to Category 1 of Section 12 “Directors Compensation and Expense Reimbursement”

No action was taken on this matter.

2.4

Public Relations

Mrs. Perea reported that Santana High School was selected to participate in Solar Cup this year. The first boat building workshop will be held on November 5, 2016 at Three Valleys. The Solar Cup event will be held May 19-21, 2017. The National Theatre for Children has scheduled performances at Wedgeworth Elementary in October, 2016 and Rorimer Elementary in November, 2016. The Buckboard Days Parade Program Ad “Celebrating Our H2o Heroes” has been delivered to the program committee and we are in the process of taking a t-shirt count to have the t-shirts made up. The parade date is October 15, 2016.

Communications Outreach

Erin LaCombe Gilhuly, CV Strategies, advised that she is continuing to work with Brittne on preparing press releases on the Conflict of Interest Code and the annual Budget. CV Strategies is in the process of completing the sponsor ads for the Buckboard Days Parade and the ForUs Foundation as well as designing the t-shirts for the Buckboard Days Parade. They are also in the process of preparing the 218 Notice and have completed a video featuring Rowland Water District’s intern program which will be shown at the ACWA Conference in November.

Education Update.

No comments.

2.9

Discussion of Upcoming Conferences, Workshops, or Events (Including Items that May Have Arisen after the Posting of the Agenda)

- Three Valleys Leadership Breakfast, Sheraton Fairplex Suites, Pomona, CA, October 27, 2016, 7:30-9:00 a.m.

Staff was asked to make reservations for the following Directors:
Director Lima, Director Lewis, Director Bellah, and Director Lu-Yang

Tab 3 LEGISLATIVE INFORMATION

3.1

Updates on Legislative Issues

None.

Tab 4

REVIEW OF CORRESPONDENCE

None.

Tab 5

COMMITTEE REPORTS

5.1

Three Valleys Municipal Water District

Director Lima reported on his attendance at the September 7, 2016 meeting and advised that they presented their Annual Investment Report for review. They advised that they were preparing the Resolution opposing Proposition 53.

5.2

Joint Powers Insurance Authority

Nothing to report.

5.3

Association of California Water Agencies

Nothing to report.

5.4

Puente Basin Water Agency

Director Lewis reported on the meeting held on September 6, 2016, and advised that all projects are proceeding as anticipated. Director Lima advised that the Fourth Quarter FY 2015-16 Financial Statements were reviewed. Mr. Coleman advised that he had received an e-mail from La Habra Heights County Water District providing several possible meeting dates to discuss billing items. He is hopeful that the meeting will take place sometime in September between La Habra, Orchard Dale, Walnut and Rowland's finance managers.

5.5

Project Ad-Hoc Committee

Nothing to report.

5.6

Regional Chamber of Commerce

Director Lewis reported that Los Angeles County Measures A and M were discussed.

5.7

PWR Joint Water Line Commission

Nothing to report. The next meeting is scheduled for October 13, 2016.

5.8

Sheriff's Community Advisory Council

Nothing to report.

Tab 6 OTHER REPORTS, INFORMATION ITEMS AND COMMENTS

6.1

Finance Report

Finance Officer, Sean Henry, reported he has been working on the rate study with NBS and also on the annual audit which should be completed in November. He also advised that the water supply allocation and conservation levels had remained comparable in July and August of this year to July and August of last year.

6.2

Operations Report

Nothing to report.

6.3

Personnel Report

Nothing to report.

Tab 7 ATTORNEY'S REPORT.

Nothing to report.

Directors' and General Manager's Comments

None.

Future Agenda Items

- Review and discuss Ethics Guidelines for Directors

Late Business

None.

A motion was made by Director Lima, seconded by Director Rios, and unanimously carried to adjourn the meeting. The meeting was adjourned at 6:51 p.m.

SZU PEI LU-YANG
Board President

Attest: _____
TOM COLEMAN
Board Secretary

Tab

1.2



Minutes of the Special Meeting of
the Board of Directors of the Rowland Water District

September 27, 2016 – 5:00 p.m.

Location: District Office

PLEDGE OF ALLEGIANCE

ROLL CALL OF DIRECTORS

President Szu Pei Lu-Yang
Vice President Robert W. Lewis
Director Anthony J. Lima
Director John Bellah
Director Teresa P. Rios

ABSENT:

None.

OTHERS PRESENT:

Joseph Byrne, Legal Counsel, Best Best & Krieger
Erin La Combe Gilhuly, CV Strategies

ROWLAND WATER DISTRICT STAFF:

Tom Coleman, General Manager
Rose Perea, Director of Administrative Services
Dave Warren, Director of Operations
Sean Henry, Finance Officer

ADDITION(S) TO THE AGENDA

None.

PUBLIC COMMENT ON NON-AGENDA ITEMS

COMMENTS:

None.

Tab 1 ACTION ITEMS

1.1

Water Rate Study Workshop

A presentation to the Board was made by Kim Boehler, Project Manager/Senior Consultant, NBS Government Finance Group, setting forth the background information used in modifying the rates and service charges. Ms. Boehler and Mr. Coleman answered questions posed by members of the Board and after a thorough discussion, Mr. Coleman advised the Board that the new rates and charges would be presented at a public hearing for Board approval and implementation in 2017.

Directors' and General Manager's Comments

None.

Future Agenda Items

None.

Late Business

None

Next Special Board Meeting

September 28, 2016, 6:00 p.m.

Next Regular Board Meeting

October 11, 2016, 6:00 p.m.

A motion was made by Director Lima, seconded by Director Rios, and unanimously carried to adjourn the meeting. The meeting was adjourned at 6:39 p.m.

SZU PEI LU-YANG
Board President

Attest: _____
TOM COLEMAN
Board Secretary

Tab

1.3



Minutes of the Special Meeting of
the Board of Directors of the Rowland Water District

September 28, 2016 – 6:00 p.m.
Location: District Office

PLEDGE OF ALLEGIANCE

ROLL CALL OF DIRECTORS

President Szu Pei Lu-Yang
Vice President Robert W. Lewis
Director Anthony J. Lima
Director John Bellah
Director Teresa P. Rios

ABSENT:

None.

OTHERS PRESENT:

None.

ROWLAND WATER DISTRICT STAFF:

Tom Coleman, General Manager

ADDITION(S) TO THE AGENDA

None.

PUBLIC COMMENT ON NON-AGENDA ITEMS

COMMENTS:

None.

Tab 1 ACTION ITEMS

1.1 CLOSED SESSION

President Lu-Yang adjourned the meeting to closed session at 6:05 p.m. and announced that the purpose of the closed session, and the provision of the Brown Act authorizing the closed session were listed in the agenda.

- a. Public Employee Performance Evaluation Pursuant to Government Code Section 54957.** Performance Review for General Manager.

The closed session was adjourned and the Board resumed the meeting in open session at 8:52 p.m. President Lu-Yang reported in open session that no reportable action was taken.

Directors' and General Manager's Comments

Future Agenda Items

None.

Late Business

None

Next Regular Board Meeting

October 11, 2016, 6:00 p.m.

A motion was made by Director Lima, seconded by Director Rios, and unanimously carried to adjourn the meeting. The meeting was adjourned at 8:54 p.m.

SZU PEI LU-YANG
Board President

Attest: _____
TOM COLEMAN
Board Secretary

Tab

1.4

Report Criteria:

Report type: GL detail

GL Period	Check Issue Date	Check Number	Vendor Number	Payee	Description	Check Amount
21685						
08/16	08/03/2016	21685	1050	ACWA JOINT POWERS INSURANCE A	UNDERGROUND STORAGE LIABILITY	1,158.00
Total 21685:						1,158.00
21686						
08/16	08/03/2016	21686	62622	AKM CONSULTING ENGINEERS	STRUCTURAL EVALUATION OF RES. 11	1,080.00
Total 21686:						1,080.00
21687						
08/16	08/03/2016	21687	62093	ASTRA INDUSTRIAL SERVICES INC	SUPPLIES FOR RES	85.27
Total 21687:						85.27
21688						
08/16	08/03/2016	21688	62597	BEST BEST & KRIEGER	LEGAL FEES-GENERAL COUNSEL	6,774.00
08/16	08/03/2016	21688	62597	BEST BEST & KRIEGER	LEGAL FEES-WATER LAW	339.00
08/16	08/03/2016	21688	62597	BEST BEST & KRIEGER	LEGAL FEES-CELL LEASES & RELATED ISSUES	1,234.80
Total 21688:						8,347.80
21689						
08/16	08/03/2016	21689	62524	BRITTNIE VAN DE CAR	MILEAGE REIMBURSEMENT	16.20
Total 21689:						16.20
21690						
08/16	08/03/2016	21690	62458	BUCKBOARD DAYS PARADE COMMIT	SPONSORSHIP-BUCKBOARD DAY PARADE	500.00
Total 21690:						500.00
21691						
08/16	08/03/2016	21691	62647	COMMLINE, INC.	TROUBLESHOOT RADIO TRUCK F-150 UNIT 3	175.00
Total 21691:						175.00
21692						
08/16	08/03/2016	21692	2125	DANIELS TIRE SERVICE	TIRES FOR BACKHOE	669.93
Total 21692:						669.93
21693						
08/16	08/03/2016	21693	32	DAVE MILLER	MILEAGE REIMBURSEMENT	61.56
Total 21693:						61.56
21694						
08/16	08/03/2016	21694	16	DAVE WARREN	TOTAL EXPENSES-GAS	140.16
Total 21694:						140.16
21695						
08/16	08/03/2016	21695	33	DUSTIN T MOISIO	MILEAGE REIMBURSEMENT	43.20

GL Period	Check Issue Date	Check Number	Vendor Number	Payee	Description	Check Amount
Total 21695:						43.20
21696						
08/16	08/03/2016	21696	330	FUEL PRO INC	D/O INSPECTION	191.80
Total 21696:						191.80
21697						
08/16	08/03/2016	21697	24701	GRAINGER	SUPPLIES FOR VEHICLES	59.04
Total 21697:						59.04
21698						
08/16	08/03/2016	21698	379	HIGHROAD INFORMATION TECHNOL	STANDARD SSL ANNUAL RENEWAL 1 YR	200.00
Total 21698:						200.00
21699						
08/16	08/03/2016	21699	27211	HILL BROS CHEMICAL CO	CHEMICAL FOR RES	1,287.29
Total 21699:						1,287.29
21700						
08/16	08/03/2016	21700	244	INFOSEND INC	BILLING SERVICE	3,068.42
08/16	08/03/2016	21700	244	INFOSEND INC	BILLING SERVICE	2,248.75
Total 21700:						5,317.17
21701						
08/16	08/03/2016	21701	62624	INTER VALLEY POOL SUPPLY INC	CHEMICALS FOR RCS	148.72
08/16	08/03/2016	21701	62624	INTER VALLEY POOL SUPPLY INC	CHEMICALS FOR RCS	266.77
08/16	08/03/2016	21701	62624	INTER VALLEY POOL SUPPLY INC	CHEMICALS FOR RCS	193.18
08/16	08/03/2016	21701	62624	INTER VALLEY POOL SUPPLY INC	CHEMICALS FOR RCS	190.11
08/16	08/03/2016	21701	62624	INTER VALLEY POOL SUPPLY INC	CHEMICALS FOR RCS	285.17
08/16	08/03/2016	21701	62624	INTER VALLEY POOL SUPPLY INC	CHEMICALS FOR RCS	125.72
08/16	08/03/2016	21701	62624	INTER VALLEY POOL SUPPLY INC	CHEMICALS FOR RCS	151.79
Total 21701:						1,361.46
21702						
08/16	08/03/2016	21702	3300	LAGERLOF SENEAL ET AL	ATTORNEY FEES-1/15TH	204.42
Total 21702:						204.42
21703						
08/16	08/03/2016	21703	62501	LEVEL 3 COMMUNICATIONS LLC	INTERNET & DATA	1,508.73
Total 21703:						1,508.73
21704						
08/16	08/03/2016	21704	28	MARCOS ASPEITIA IV	MILEAGE REIMBURSEMENT	34.56
08/16	08/03/2016	21704	28	MARCOS ASPEITIA IV	TOTAL EXPENSES-BACKFLOW CERT TEST	180.00
08/16	08/03/2016	21704	28	MARCOS ASPEITIA IV	TOTAL EXPENSES-BACKFLOW REFRESHER CLAS	8.19
Total 21704:						222.75

GL Period	Check Issue Date	Check Number	Vendor Number	Payee	Description	Check Amount
21705						
08/16	08/03/2016	21705	62078	MCKINNEY CONSTRUCTION CO INC	FURNISHED AND INSTALLED TEE, FIRE HYDRANT	14,870.00
08/16	08/03/2016	21705	62078	MCKINNEY CONSTRUCTION CO INC	ADDITIONAL LABOR, EQUIPMENT & MATERIAL TO	2,909.37
08/16	08/03/2016	21705	62078	MCKINNEY CONSTRUCTION CO INC	FURNISHED AND INSTALLED 2" SHORT SIDE IRR	10,050.00
08/16	08/03/2016	21705	62078	MCKINNEY CONSTRUCTION CO INC	FURNISHED AND INSTALLED 4 X 3 LONG SIDE WA	17,750.00
08/16	08/03/2016	21705	62078	MCKINNEY CONSTRUCTION CO INC	EMERGENCY LEAK ON 16" WATER MAIN-VALLEY/	28,299.33
Total 21705:						73,878.70
21706						
08/16	08/03/2016	21706	62448	PARS	GASBY 45 MANAGEMENT FEE	472.58
Total 21706:						472.58
21707						
08/16	08/03/2016	21707	62447	REEB GOVERNMENT RELATIONS LLC	LOBBYIST	1,500.00
Total 21707:						1,500.00
21708						
08/16	08/03/2016	21708	62062	ROBERT LEAMY	MILEAGE REIMBURSEMENT	20.70
Total 21708:						20.70
21709						
08/16	08/03/2016	21709	62460	RYAN WHITE	MILEAGE REIMBURSEMENT	50.65
Total 21709:						50.65
21710						
08/16	08/03/2016	21710	62194	SCEC C/O MONTROSE ENVIROMENT	SOURCE EMISSIONS TESTING - NATURAL GAS EN	1,800.00
Total 21710:						1,800.00
21711						
08/16	08/03/2016	21711	62046	SGV REGIONAL CHAMBER OF COMM	REGIONAL CHAMBER LEGISLATIVE POWER LUNC	50.00
Total 21711:						50.00
21712						
08/16	08/03/2016	21712	2180	SWRCB-DWOCP	T2 RENEWAL-DAVE MILLER	60.00
Total 21712:						60.00
21713						
08/16	08/03/2016	21713	62521	TRIEPEI SMITH & ASSOCIATES	MONTHLY WEBSITE MAINTENANCE	300.00
Total 21713:						300.00
21714						
08/16	08/03/2016	21714	62406	UNITED RENTALS	GAS AUGER	149.53
08/16	08/03/2016	21714	62406	UNITED RENTALS	COMPRESSOR TOW HITCH	21.60
Total 21714:						171.13
21715						
08/16	08/03/2016	21715	205	WARREN GRAPHICS	DISTRICT RULES & REGS	419.04

GL Period	Check Issue Date	Check Number	Vendor Number	Payee	Description	Check Amount
Total 21715:						419.04
21716						
08/16	08/03/2016	21716	62046	SGV REGIONAL CHAMBER OF COMM	REGIONAL CHAMBER LEGISLATIVE POWER LUNC	50.00
Total 21716:						50.00
21718						
08/16	08/09/2016	21718	62233	JOHN BELLAH	TOTAL EXPENSES-CSDA CONFERENCE	321.49
08/16	08/09/2016	21718	62233	JOHN BELLAH	NON REIMBURSABLE EXPENSES-CSDA CONFERE	64.86-
Total 21718:						256.63
21719						
08/16	08/16/2016	21719	4750	PWR JT WATER LINE COMMISSION	438.2 AC FT-JUNE 2016 WATER	402,267.60
08/16	08/16/2016	21719	4750	PWR JT WATER LINE COMMISSION	MWD CAPACITY RESERVATION CHARGE	10,739.20
08/16	08/16/2016	21719	4750	PWR JT WATER LINE COMMISSION	TVMWD CONNECTED CAPACITY CHARGE	1,149.69
08/16	08/16/2016	21719	4750	PWR JT WATER LINE COMMISSION	TVMWD WATER USE CHARGE	1,992.76
08/16	08/16/2016	21719	4750	PWR JT WATER LINE COMMISSION	BUDGET ASSESSMENT-2ND QUARTER	12,080.96
Total 21719:						428,230.21
21720						
08/16	08/22/2016	21720	1000	ACWA JPIA	EMPLOYEE HEALTH BENEFITS	29,804.26
08/16	08/22/2016	21720	1000	ACWA JPIA	EMPLOYEE VISION BENEFITS	444.78
08/16	08/22/2016	21720	1000	ACWA JPIA	EMPLOYEE ASSISTANCE PROGRAM	49.35
08/16	08/22/2016	21720	1000	ACWA JPIA	EMPLOYEE DENTAL BENEFITS	2,647.69
08/16	08/22/2016	21720	1000	ACWA JPIA	RETIREEES HEALTH BENEFITS	11,331.91
08/16	08/22/2016	21720	1000	ACWA JPIA	DIRECTORS HEALTH BENEFITS	7,402.61
Total 21720:						51,680.60
21721						
08/16	08/22/2016	21721	1625	ANTHEM BLUE CROSS	RETIREE HEALTH BENEFITS	1,764.62
Total 21721:						1,764.62
21722						
08/16	08/22/2016	21722	3850	ATHENS SERVICES (MODERN SVC)	TRASH SERVICE	257.88
08/16	08/22/2016	21722	3850	ATHENS SERVICES (MODERN SVC)	DUMP 30YD TRASH BIN	505.81
Total 21722:						763.69
21723						
08/16	08/22/2016	21723	6966	CINTAS CORPORATION LOC 693	UNIFORM RENTAL	2,679.84
Total 21723:						2,679.84
21724						
08/16	08/22/2016	21724	62309	CITY OF INDUSTRY CITY HALL	RECYCLED WATER SYSTEM	30,046.52
Total 21724:						30,046.52
21725						
08/16	08/22/2016	21725	22541	DOTY BROS CONSTRUCTION CO	REPLACE 3/4" W/1"-2128 TOMICH RD	6,930.00

GL Period	Check Issue Date	Check Number	Vendor Number	Payee	Description	Check Amount
Total 21725:						6,930.00
21726						
08/16	08/22/2016	21726	62445	EXCEL DOOR & GATE COMPANY	PERFORM SERVICE AND REPAIRS ON DOOR	780.00
Total 21726:						780.00
21727						
08/16	08/22/2016	21727	5600	G M SAGER CONSTRUCTION	ASPHALT & CONCRETE	7,038.70
Total 21727:						7,038.70
21728						
08/16	08/22/2016	21728	24701	GRAINGER	TOOLS & SUPPLIES	282.03
Total 21728:						282.03
21729						
08/16	08/22/2016	21729	2600	HACH COMPANY	WATER QUALITY TESTING SUPPLIES	736.75
Total 21729:						736.75
21730						
08/16	08/22/2016	21730	2690	HARPER & ASSOCIATES ENG.	Engineering services for the corrosion evaluation of fiv	14,700.00
Total 21730:						14,700.00
21731						
08/16	08/22/2016	21731	379	HIGHROAD INFORMATION TECHNOL	STANDARD SSL RENEWAL 1 YR FOR MAINL.ROWL	200.00
08/16	08/22/2016	21731	379	HIGHROAD INFORMATION TECHNOL	CABLE RUN TO INCREASE THE SIGNAL FOR WIRE	450.00
Total 21731:						650.00
21732						
08/16	08/22/2016	21732	2724	HOME DEPOT CREDIT SERVICES	MATERIAL & SUPPLIES	1,016.56
08/16	08/22/2016	21732	2724	HOME DEPOT CREDIT SERVICES	MATERIAL & SUPPLIES	176.53
08/16	08/22/2016	21732	2724	HOME DEPOT CREDIT SERVICES	MATERIAL & SUPPLIES	409.04
08/16	08/22/2016	21732	2724	HOME DEPOT CREDIT SERVICES	MATERIAL & SUPPLIES	69.43
Total 21732:						1,671.56
21733						
08/16	08/22/2016	21733	62435	INDUSTRY PUBLIC UTILITY COMMISS	PUMPING POWER-PUMPSTATION 2A	12,825.24
Total 21733:						12,825.24
21734						
08/16	08/22/2016	21734	244	INFOSEND INC	BILLING SERVICE	16.38
Total 21734:						16.38
21735						
08/16	08/22/2016	21735	62066	JANITORIAL SYSTEMS	WINDOW CLEANING INSIDE & OUT	300.00
08/16	08/22/2016	21735	62066	JANITORIAL SYSTEMS	MONTHLY JANITORIAL SERVICES	600.00

GL Period	Check Issue Date	Check Number	Vendor Number	Payee	Description	Check Amount
Total 21735:						900.00
21736						
08/16	08/22/2016	21736	62583	LINCOLN FINANCIAL GROUP	LIFE INSURANCE	282.69
08/16	08/22/2016	21736	62583	LINCOLN FINANCIAL GROUP	SHORT/LONG TERM DISABILITY	689.47
Total 21736:						972.16
21737						
08/16	08/22/2016	21737	62659	LOS ANGELES COUNTY ASSESSOR	PROPERTY OWNERSHIP DATA	276.00
Total 21737:						276.00
21738						
08/16	08/22/2016	21738	2052	LOS ANGELES COUNTY CLERK	NOTICE OF EXEMPTION FILING FEE	75.00
Total 21738:						75.00
21739						
08/16	08/22/2016	21739	257	MCMASTER-CARR SUPPLY CO	SUPPLIES FOR HYDRANTS	214.78
08/16	08/22/2016	21739	257	MCMASTER-CARR SUPPLY CO	TOOLS & SUPPLIES	16.54
Total 21739:						231.32
21740						
08/16	08/22/2016	21740	189	NOBEL SYSTEMS	SOFTWARE DEVELOPMENT SERVICES TO INTEG	2,000.00
Total 21740:						2,000.00
21741						
08/16	08/22/2016	21741	5100	PUENTE READY MIX INC	CRUSH BASE	753.35
Total 21741:						753.35
21742						
08/16	08/22/2016	21742	62240	REVEL ENVIRONMENTAL MFG	TOOLS & SUPPLIES	610.40
Total 21742:						610.40
21743						
08/16	08/22/2016	21743	62502	S & J SUPPLY COMPANY, INC	MATERIAL FOR MAINS	5,428.20
08/16	08/22/2016	21743	62502	S & J SUPPLY COMPANY, INC	MATERIAL FOR FULLERTON RD GRADE SEP	13,873.95
08/16	08/22/2016	21743	62502	S & J SUPPLY COMPANY, INC	MATERIAL FOR MAINS	1,361.28
08/16	08/22/2016	21743	62502	S & J SUPPLY COMPANY, INC	MATERIAL FOR MAINS	3,864.93
08/16	08/22/2016	21743	62502	S & J SUPPLY COMPANY, INC	6" SB 421 6.56-7.60 TOP-BOLT CPLG	440.00
08/16	08/22/2016	21743	62502	S & J SUPPLY COMPANY, INC	E10VCW EISEL 10 CI COVER M/WTR 1RT-3RT-2R	251.20
08/16	08/22/2016	21743	62502	S & J SUPPLY COMPANY, INC	MBW100L P/P MBW-100L SS MTR LID LIOFTER 36"	96.93
08/16	08/22/2016	21743	62502	S & J SUPPLY COMPANY, INC	6" C;PW C509 DI MJ RWGV OL L/A W/SS T316 TRIM	1,293.92
08/16	08/22/2016	21743	62502	S & J SUPPLY COMPANY, INC	CLOW 850 FIRE HYD DC 8H	1,272.80
08/16	08/22/2016	21743	62502	S & J SUPPLY COMPANY, INC	JE4201WSG1 1" E4201WSG NO LEAD CTS	360.48
08/16	08/22/2016	21743	62502	S & J SUPPLY COMPANY, INC	BECKSON HAND PUMP 136PF 6	180.00
08/16	08/22/2016	21743	62502	S & J SUPPLY COMPANY, INC	1" X 60' TYPE K SOFT COPPER	631.14
08/16	08/22/2016	21743	62502	S & J SUPPLY COMPANY, INC	MATERIAL FOR FULLERTON RD GRADE SEP	75.04
08/16	08/22/2016	21743	62502	S & J SUPPLY COMPANY, INC	MATERIAL FOR FULLERTON RD GRADE SEP	218.43
08/16	08/22/2016	21743	62502	S & J SUPPLY COMPANY, INC	MATERIAL FOR FULLERTON RD GRADE SEP	1,341.96
08/16	08/22/2016	21743	62502	S & J SUPPLY COMPANY, INC	MATERIAL FOR FULLERTON RD GRADE SEP	2,440.73

GL Period	Check Issue Date	Check Number	Vendor Number	Payee	Description	Check Amount
Total 21743:						33,130.99
21744						
08/16	08/22/2016	21744	5691	SECRETARY OF STATE	NOTARY COMMISSION FEE-R PEREA	40.00
Total 21744:						40.00
21745						
08/16	08/22/2016	21745	62166	SO CAL GAS CO	GAS UTILITY BILL-2505 ARTIGAS	52.25
Total 21745:						52.25
21746						
08/16	08/22/2016	21746	1165	TERMINIX PROCESSING CENTER	MONTHLY PEST CONTROL SERVICE	105.00
Total 21746:						105.00
21747						
08/16	08/22/2016	21747	5900	THE GAS COMPANY	GAS UTILITY BILL	20.94
Total 21747:						20.94
21748						
08/16	08/22/2016	21748	6950	UNDERGROUND SERVICE ALERT	SERVICE ALERT	220.50
Total 21748:						220.50
21749						
08/16	08/22/2016	21749	62353	VERIZON	PHONE SYSTEM-VOIP/VOICE LINE	921.87
Total 21749:						921.87
21750						
08/16	08/22/2016	21750	382	W A RASIC CONSTRUCTION CO INC	IHOP-FULLERTON RD GRADE SEP	7,362.30
08/16	08/22/2016	21750	382	W A RASIC CONSTRUCTION CO INC	JACK IN THE BOX-FULLERTON RD GRADE SEP	6,047.27
08/16	08/22/2016	21750	382	W A RASIC CONSTRUCTION CO INC	BASKIN ROBBINS-FULLERTON RD GRADE SEP	4,853.22
08/16	08/22/2016	21750	382	W A RASIC CONSTRUCTION CO INC	ADP-FULLERTON ROAD GRADE SEP	6,235.17
08/16	08/22/2016	21750	382	W A RASIC CONSTRUCTION CO INC	LASONIA SHOES-FULLERTON ROAD GRADE SEP	4,717.29
08/16	08/22/2016	21750	382	W A RASIC CONSTRUCTION CO INC	IWG-FULLERTON RD GRADE SEP	3,611.65
08/16	08/22/2016	21750	382	W A RASIC CONSTRUCTION CO INC	PANCHEROS-FULLERTON RD GRADE SEP	8,877.53
08/16	08/22/2016	21750	382	W A RASIC CONSTRUCTION CO INC	CATHAY BANK-FULLERTON RD GRADE SEP	16,429.52
08/16	08/22/2016	21750	382	W A RASIC CONSTRUCTION CO INC	ASTRO SPAR-FULLERTON RD GRADE SEP	5,443.26
08/16	08/22/2016	21750	382	W A RASIC CONSTRUCTION CO INC	FORMERLY HANDBAG REP-FULLERTON RD GRAD	4,340.69
08/16	08/22/2016	21750	382	W A RASIC CONSTRUCTION CO INC	LEE & RO-FULLERTON RD GRADE SEP	8,368.43
08/16	08/22/2016	21750	382	W A RASIC CONSTRUCTION CO INC	OFF SITE PHASE 1 FULLERTON RD GRADE SEP	7,204.26
08/16	08/22/2016	21750	382	W A RASIC CONSTRUCTION CO INC	FEDEX-FULLERTON RD GRADE SEP	7,287.94
08/16	08/22/2016	21750	382	W A RASIC CONSTRUCTION CO INC	NEXT DOOR TO ASTRO SPAR-FULLERTON RD GR	7,254.29
Total 21750:						98,032.82
21751						
08/16	08/22/2016	21751	205	WARREN GRAPHICS	NEW CONSERVATION FLYER	2,403.00
Total 21751:						2,403.00

GL Period	Check Issue Date	Check Number	Vendor Number	Payee	Description	Check Amount
21752						
08/16	08/22/2016	21752	382	W A RASIC CONSTRUCTION CO INC	NOGALES GRADE SEPARATION	14,204.50
Total 21752:						14,204.50
21753						
08/16	08/22/2016	21753	62353	VERIZON	CONFERENCE CALLS	60.78
Total 21753:						60.78
21754						
08/16	08/22/2016	21754	382	W A RASIC CONSTRUCTION CO INC	PROJECT 15SX87-FULLERTON RD	482.77
08/16	08/22/2016	21754	382	W A RASIC CONSTRUCTION CO INC	PROJECT 15SX88-FULLERTON RD	482.77
08/16	08/22/2016	21754	382	W A RASIC CONSTRUCTION CO INC	PROJECT 15SX90-FULLERTON RD	482.77
08/16	08/22/2016	21754	382	W A RASIC CONSTRUCTION CO INC	PROJECT 15SX91-FULLERTON RD	482.77
08/16	08/22/2016	21754	382	W A RASIC CONSTRUCTION CO INC	PROJECT 15SX92-FULLERTON RD	482.79
08/16	08/22/2016	21754	382	W A RASIC CONSTRUCTION CO INC	PROJECT 15SX93-FULLERTON RD	482.79
08/16	08/22/2016	21754	382	W A RASIC CONSTRUCTION CO INC	PROJECT 15SX94-FULLERTON RD	932.72
08/16	08/22/2016	21754	382	W A RASIC CONSTRUCTION CO INC	PROJECT 15SX95-FULLERTON RD	3,204.40
08/16	08/22/2016	21754	382	W A RASIC CONSTRUCTION CO INC	PROJECT 15SX96-FULLERTON RD	482.79
08/16	08/22/2016	21754	382	W A RASIC CONSTRUCTION CO INC	PROJECT 15SX97-FULLERTON RD	469.33
08/16	08/22/2016	21754	382	W A RASIC CONSTRUCTION CO INC	PROJECT 15SX98-FULLERTON RD	2,320.37
08/16	08/22/2016	21754	382	W A RASIC CONSTRUCTION CO INC	PROJECT 15TX15-FULLERTON RD	739.28
08/16	08/22/2016	21754	382	W A RASIC CONSTRUCTION CO INC	PROJECT 15TX16-FULLERTON RD	1,353.22
08/16	08/22/2016	21754	382	W A RASIC CONSTRUCTION CO INC	PROJECT 15TX17-FULLERTON RD	1,436.48
Total 21754:						13,835.25
21755						
08/16	08/22/2016	21755	382	W A RASIC CONSTRUCTION CO INC	PROJECT 15SX87-FULLERTON RD	21,367.51
08/16	08/22/2016	21755	382	W A RASIC CONSTRUCTION CO INC	PROJECT 15SX88-FULLERTON RD	16,741.49
08/16	08/22/2016	21755	382	W A RASIC CONSTRUCTION CO INC	PROJECT 15SX90-FULLERTON RD	1,438.53
08/16	08/22/2016	21755	382	W A RASIC CONSTRUCTION CO INC	PROJECT 15SX91-FULLERTON RD	19,545.78
08/16	08/22/2016	21755	382	W A RASIC CONSTRUCTION CO INC	PROJECT 15SX92-FULLERTON RD	578.49
08/16	08/22/2016	21755	382	W A RASIC CONSTRUCTION CO INC	PROJECT 15SX93-FULLERTON RD	550.83
08/16	08/22/2016	21755	382	W A RASIC CONSTRUCTION CO INC	PROJECT 15SX94-FULLERTON RD	7,227.02
08/16	08/22/2016	21755	382	W A RASIC CONSTRUCTION CO INC	PROJECT 15SX95-FULLERTON RD	21,557.26
08/16	08/22/2016	21755	382	W A RASIC CONSTRUCTION CO INC	PROJECT 15SX96-FULLERTON RD	208.83
08/16	08/22/2016	21755	382	W A RASIC CONSTRUCTION CO INC	PROJECT 15SX97-FULLERTON RD	708.91
08/16	08/22/2016	21755	382	W A RASIC CONSTRUCTION CO INC	PROJECT 15SX98-FULLERTON RD	1,513.65
08/16	08/22/2016	21755	382	W A RASIC CONSTRUCTION CO INC	PROJECT 15TX15-FULLERTON RD	11,931.37
08/16	08/22/2016	21755	382	W A RASIC CONSTRUCTION CO INC	PROJECT 15TX16-FULLERTON RD	117.94
08/16	08/22/2016	21755	382	W A RASIC CONSTRUCTION CO INC	PROJECT 15TX17-FULLERTON RD	90.28
Total 21755:						103,577.89
81516						
08/16	08/15/2016	81516	62558	PUENTE BASIN WATER AGENCY	PM 22/PM 9 CONNECTION	417,690.00
08/16	08/15/2016	81516	62558	PUENTE BASIN WATER AGENCY	TVMWD CONNECTION CAPACITY	1,425.23
08/16	08/15/2016	81516	62558	PUENTE BASIN WATER AGENCY	TVMWD EQUIVALENT SMALL METER	1,828.86
08/16	08/15/2016	81516	62558	PUENTE BASIN WATER AGENCY	TVMWD WATER USE CHARGE	1,457.58
08/16	08/15/2016	81516	62558	PUENTE BASIN WATER AGENCY	MWD CAPACITY CHARGE	11,203.21
08/16	08/15/2016	81516	62558	PUENTE BASIN WATER AGENCY	MWD LRP CREDIT	7,715.00-
Total 81516:						425,889.88

GL Period	Check Issue Date	Check Number	Vendor Number	Payee	Description	Check Amount
81916						
08/16	08/19/2016	81916	5800	SO CALIFORNIA EDISON	OFFICE & PUMPING POWER	10,464.29
08/16	08/19/2016	81916	5800	SO CALIFORNIA EDISON	OFFICE & PUMPING POWER	1,162.70
Total 81916:						11,626.99
82216						
08/16	08/22/2016	82216	1070	AMERICAN EXPRESS	VEHICLE EXPENSES	135.00
08/16	08/22/2016	82216	1070	AMERICAN EXPRESS	COI EXPENSE	449.74
08/16	08/22/2016	82216	1070	AMERICAN EXPRESS	SEMINARS & TRAINING EXPENSE	3,493.00
08/16	08/22/2016	82216	1070	AMERICAN EXPRESS	MISC EXPENSES	576.40
08/16	08/22/2016	82216	1070	AMERICAN EXPRESS	CONFERENCE EXPENSES	5,751.04
08/16	08/22/2016	82216	1070	AMERICAN EXPRESS	WATER CONSERVATION PROGRAM	14,735.26
Total 82216:						25,140.44
Grand Totals:						1,397,536.68

Summary by General Ledger Account Number

GL Account	Debit	Credit	Proof
11505-0	300,184.94	.00	300,184.94
222100	7,779.86	1,405,316.54-	1,397,536.68-
51310-0	819,957.60	7,715.00-	812,242.60
51410-1	3,450.34	.00	3,450.34
51410-2	2,574.92	.00	2,574.92
51410-3	1,828.86	.00	1,828.86
51410-5	21,942.41	.00	21,942.41
51510-0	30,046.52	.00	30,046.52
51810-0	12,080.96	.00	12,080.96
52310-0	23,289.53	.00	23,289.53
54210-0	40,147.09	.00	40,147.09
54211-0	7,669.84	.00	7,669.84
54212-0	457.41	.00	457.41
54213-0	16,041.80	.00	16,041.80
54214-0	1,545.12	.00	1,545.12
54215-0	1,896.62	.00	1,896.62
54217-0	2,648.75	.00	2,648.75
54218-0	449.74	.00	449.74
54219-0	69.43	.00	69.43
56210-0	1,179.13	.00	1,179.13
56211-0	472.58	.00	472.58
56215-0	40.00	.00	40.00
56216-0	419.04	.00	419.04
56217-0	226.87	.00	226.87
56218-0	9,847.80	.00	9,847.80
56218-2	204.42	.00	204.42
56219-0	2,982.23	.00	2,982.23
56220-0	4,658.73	.00	4,658.73
56221-0	2,903.00	.00	2,903.00
56223-0	6,072.53	64.86-	6,007.67
56310-0	1,158.00	.00	1,158.00
56312-0	9,238.89	.00	9,238.89
56320-0	3,601.19	.00	3,601.19

GL Account	Debit	Credit	Proof
56411-0	29,804.26	.00	29,804.26
56413-0	2,647.69	.00	2,647.69
56415-0	444.78	.00	444.78
56416-0	282.69	.00	282.69
56417-0	13,096.53	.00	13,096.53
56418-0	689.47	.00	689.47
56419-0	49.35	.00	49.35
56421-0	7,402.61	.00	7,402.61
56510-0	276.00	.00	276.00
56710-0	171.13	.00	171.13
56812-0	576.40	.00	576.40
57312-0	2,105.53	.00	2,105.53
57314-0	780.00	.00	780.00
57319-0	14,735.26	.00	14,735.26
57320-0	60.00	.00	60.00
57321-0	2,908.55	.00	2,908.55
Grand Totals:	<u>1,413,096.40</u>	<u>1,413,096.40-</u>	<u>.00</u>

Report Criteria:
 Report type: GL detail

Tab

1.5



Rowland Water District Memorandum

To: Thomas Coleman, General Manager

From: Sean S. Henry, Finance Officer

CC:

Date: September 1, 2016

Subject: Investment Update – August 2016

Economic Review: The next meeting of the Federal Reserve is scheduled for September 20th. The last meeting was held on July 26th. The Fed Funds rate was maintained at a target range of $\frac{1}{4}$ to $\frac{1}{2}$ percent. At the meeting, the Federal Reserve stated “the labor market strengthened and economic activity has been expanding at a moderate rate. Job gains were strong in June following weak growth in May. On balance, payrolls and other labor market indicators point to some increase in labor utilization in recent months. Household spending has been growing strongly but business fixed investment has been soft. Inflation has continued to run below the Committee’s two percent longer-run objective, partly reflecting earlier declines in energy prices and in prices of non-energy imports.” The latest reading of the Consumer Price Index (CPI) for Los Angeles, Riverside and Orange Counties was 1.8 for the month of July. The previous reading was 1.2 in June.

LAIF Update: LAIF ended the month of July with a yield of 0.59%. This represents a .01 basis point increase from the month of June. A comparison with last year shows a .27 basis point increase from July 2017 when the yield stood at 0.32%.

RWD Investments: Rowland Water District’s bond portfolio carries an average yield of 1.16%. This represents a .01 basis point increase from the month of July and a 0.57 basis point premium to LAIF. The District had one bond purchase and mature in the month of August. A five year \$250,000 US Treasury yielding 1.50% matured on August 1st and a five year \$250,000 US Treasury yielding 1.125% was purchased. The District CD Placement program carries an effective yield of 0.93% and an average maturity of 633 days.

Rowland Water District
3021 South Fullerton Road
Rowland Heights, CA 91748
Tel (562) 697-1726

ROWLAND WATER DISTRICT
SUMMARY OF CASH AND INVESTMENTS
FOR MONTH ENDED AUGUST 31, 2016



CASH	
Citizens Business Bank	1,207,136.94
Comerica Bank MMIA	26,092.65
TOTAL CASH	1,233,229.59

COMERICA SECURITIES CD PLACEMENT	NA	1mth - 2 Years	NA	NA	NA	0.93%	633	2,190,000.00	12.24%
LOCAL AGENCY INVESTMENT FUND (LAIF)	NA	NA	NA	NA	NA	0.59%	NA	1,927,159.87	10.77%

BNY MELLON INVESTMENTS
(UNION BANK CUSTODIAN)

	Term	Quantity	Purchase Price	Current Price	Maturity Date	Effective Yield	Next Call	Current Value	% of Portfolio
US Treasury Note	5 Year	250,000.00	101.231	100.117	10/31/16	1.00%	NA	250,292.50	1.40%
Fedl Natl Mtg Assn	5 Year	250,000.00	100.639	100.199	11/15/16	1.38%	NA	250,497.50	1.40%
US Treasury Note	5 Year	250,000.00	99.942	100.134	11/30/16	0.88%	NA	250,335.00	1.40%
Fed Natl Mtg Assn	5 Year	200,000.00	101.194	100.314	01/30/17	1.25%	NA	200,628.00	1.12%
Fed Natl Mtg Assn	5 Year	250,000.00	100.083	100.189	08/28/17	0.88%	NA	250,472.50	1.40%
US Treasury Note	5 Year	250,000.00	99.559	99.914	09/30/17	0.63%	NA	249,785.00	1.40%
Fed Natl Mtg Assn	5 Year	250,000.00	100.019	100.109	12/20/17	0.88%	NA	250,272.50	1.40%
Fed Home Loan Mtg Corp	5 Year	200,000.00	99.289	99.894	01/12/18	0.75%	NA	199,788.00	1.12%
US Treasury Note	5 Year	200,000.00	99.742	99.973	02/28/18	0.75%	NA	199,946.00	1.12%
US Treasury Note	4 Year	250,000.00	99.539	101.035	06/30/18	1.38%	NA	252,587.50	1.41%
Fed Natl Mtg Assn	5 Year	500,000.00	100.300	100.073	05/21/18	0.88%	NA	500,365.00	2.80%
US Treasury Note	5 Year	250,000.00	99.727	101.141	09/30/18	1.38%	NA	252,852.50	1.41%
US Treasury Note	5 Year	250,000.00	99.868	101.191	11/30/18	1.38%	NA	252,977.50	1.41%
US Treasury Note	5 Year	250,000.00	99.137	101.488	12/31/18	1.50%	NA	253,720.00	1.41%
US Treasury Note	5 Year	250,000.00	100.172	101.520	01/31/19	1.50%	NA	253,800.00	1.41%
US Treasury Note	5 Year	250,000.00	99.140	101.574	02/28/19	1.50%	NA	253,935.00	1.42%
US Treasury Note	5 Year	250,000.00	99.617	101.906	03/31/19	1.63%	NA	254,765.00	1.42%
US Treasury Note	5 Year	250,000.00	98.719	100.996	04/30/19	1.26%	NA	252,490.00	1.42%
US Treasury Note	5 Year	100,000.00	98.532	100.910	10/31/19	1.27%	NA	100,910.00	1.42%
US Treasury Note	5 Year	250,000.00	99.359	101.219	01/31/20	1.38%	NA	253,047.50	1.41%
US Treasury Note	5 Year	250,000.00	99.047	100.336	03/31/20	1.14%	NA	250,840.00	0.56%
US Treasury Note	5 Year	250,000.00	99.016	101.176	04/30/20	1.38%	NA	252,940.00	1.41%
Fed Natl Mtg Assn	5 Year	250,000.00	98.867	101.780	06/22/20	1.50%	NA	253,302.50	1.40%
US Treasury Note	5 Year	250,000.00	99.633	99.867	02/28/21	1.13%	NA	249,667.50	1.41%
US Treasury Note	5 Year	250,000.00	100.184	99.672	07/31/21	1.13%	NA	249,180.00	1.42%
Cash Reserve Account						0.03%		71,172.37	0.40%
Total BNY Mellon Investments								6,310,569.37	35.28%

MERRILL LYNCH INVESTMENTS
(UNION BANK CUSTODIAN)

	Term	Quantity	Purchase Price	Current Price	Maturity Date	Effective Yield	Next Call	Current Value	% of Portfolio
Fedl Natl Mtg Assn	5 Year	480,000.00	100.761	100.067	09/28/16	1.25%	NA	480,321.60	2.69%
Fedl Natl Mtg Assn	5 Year	500,000.00	100.898	100.199	11/15/16	1.38%	NA	500,995.00	2.80%
Fedl Home Loan Mtg Corp	5 Year	465,000.00	100.427	100.215	03/08/17	1.00%	NA	465,999.75	2.61%
Fedl Home Loan Mtg Corp	5 Year	250,000.00	102.124	100.472	05/12/17	1.25%	NA	251,180.00	1.40%
Fedl Home Loan Mtg Corp	5 Year	250,000.00	100.793	100.291	06/29/17	1.00%	NA	250,727.50	1.40%
Fedl Natl Mtg Assn	5 Year	485,000.00	101.342	100.189	08/28/17	0.88%	NA	485,916.65	2.72%
Fedl Natl Mtg Assn	5 Year	495,000.00	100.650	100.109	12/20/17	0.88%	NA	495,539.55	2.77%
Fedl Home Loan Mtg Corp	5 Year	495,000.00	100.066	99.894	01/12/18	0.75%	NA	494,475.30	2.76%
Fedl Natl Mtg Assn	5 Year	495,000.00	100.448	100.044	02/08/18	0.88%	NA	495,217.80	2.77%
Fedl Home Loan Mtg Corp	5 Year	495,000.00	100.392	100.000	03/07/18	0.88%	NA	495,000.00	2.77%
Fedl Natl Mtg Assn	5 Year	500,000.00	100.530	100.073	05/21/18	0.88%	NA	500,365.00	2.80%
Fedl Natl Mtg Assn	4 Year	250,000.00	98.671	100.580	09/27/18	1.27%	NA	251,450.00	1.41%
Fedl Natl Mtg Assn	5 Year	245,000.00	100.061	101.588	11/27/18	1.63%	NA	248,890.60	1.39%
Fedl Home Loan Mtg Corp	5 Year	275,000.00	99.581	100.656	08/01/19	1.25%	NA	276,804.00	1.55%
Fedl Home Loan Mtg Corp	5 Year	275,000.00	99.344	100.636	10/02/19	1.25%	NA	276,749.00	1.55%
Fedl Farm Credit Bank	5 Year	240,000.00	98.229	100.490	10/22/19	1.29%	NA	241,176.00	1.35%
ML Bank Deposit (Cash Account)						0.03%		14,022.02	0.08%
Total Merrill Lynch Investments								6,224,829.77	34.80%

TOTAL INVESTMENTS
TOTAL CASH AND INVESTMENTS

Weighted Average Yield of Total Investment Portfolio:	0.94%
--	--------------

16,652,559.01 100%
17,885,788.60

Market values determined by last business day of month values.
All listed investments comply with the District's Statement of Investment Policy as established in Resolution 2-2007.
The District's available cash and investment portfolio provides sufficient cash flow and liquidity to meet all normal obligations for at least a six-month period of time.
NOTE: All interest values shown above are based on annual rates of return.

Sean S. Henry, Finance Officer



COMPARATIVE PURCHASED WATER REPORT FOR THE MONTH OF JULY 2016

SOURCE / DESCRIPTION	2016			2015		
	ACRE-FEET	COST	COST/A.F.	ACRE-FEET	COST	COST/A.F.
WATER CHARGES:						
POTABLE WATER						
PUENTE BASIN WATER AGENCY / TVMWD	431.3	395,933.40	918.00	353.1	299,056.90	846.95
POMONA-WALNUT-ROWLAND JWLC	536.2	492,231.60	918.00	569.6	512,070.40	899.00
LA HABRA HEIGHTS	0.0	-	-	0.0	-	-
WATER REPLENISHMENT DISTRICT (WRD)	0.0	-	-	0.0	-	-
	967.5	888,165.00		922.7	811,127.3	
RECLAIMED WATER	133.0	31,222.69	234.76	127.3	29,922.67	235.06
TOTAL WATER CHARGES	1,100.5	919,387.69		1,050.0	841,049.97	
FIXED CHARGES:						
PUENTE BASIN WATER AGENCY / TVMWD						
CAPACITY RESERVATION		11,203.21			9,993.79	
CONNECTED CAPACITY		1,425.23			1,409.90	
WATER USE CHARGE		1,457.58			1,360.71	
EQUIV. SMALL METER		1,828.86			1,665.02	
SUBTOTAL		15,914.88			14,429.42	
PWR JWLC						
CAPACITY RESERVATION		10,739.20			11,348.45	
CONNECTED CAPACITY		1,149.69			1,137.31	
WATER USE CHARGE		1,992.76			2,208.05	
DEPRECIATION		-			-	
REPLACEMENT		-			-	
BUDGET ASSESSMENT		-			-	
SUBTOTAL		13,881.65			14,693.81	
LHH / OCWD						
WHEELING CHARGE	0.0	-	-	3.1	156.50	50.00
SUBTOTAL						
TOTAL FIXED CHARGES		29,796.53			29,123.23	
TOTAL PURCHASED WATER CHARGES		949,184.22			870,173.20	
AVERAGE WATER CHARGE:		\$ 862.50			\$ 828.74	

Tab

1.6

Potable Water Purchases For FY 2016-2017

(Acre-feet)

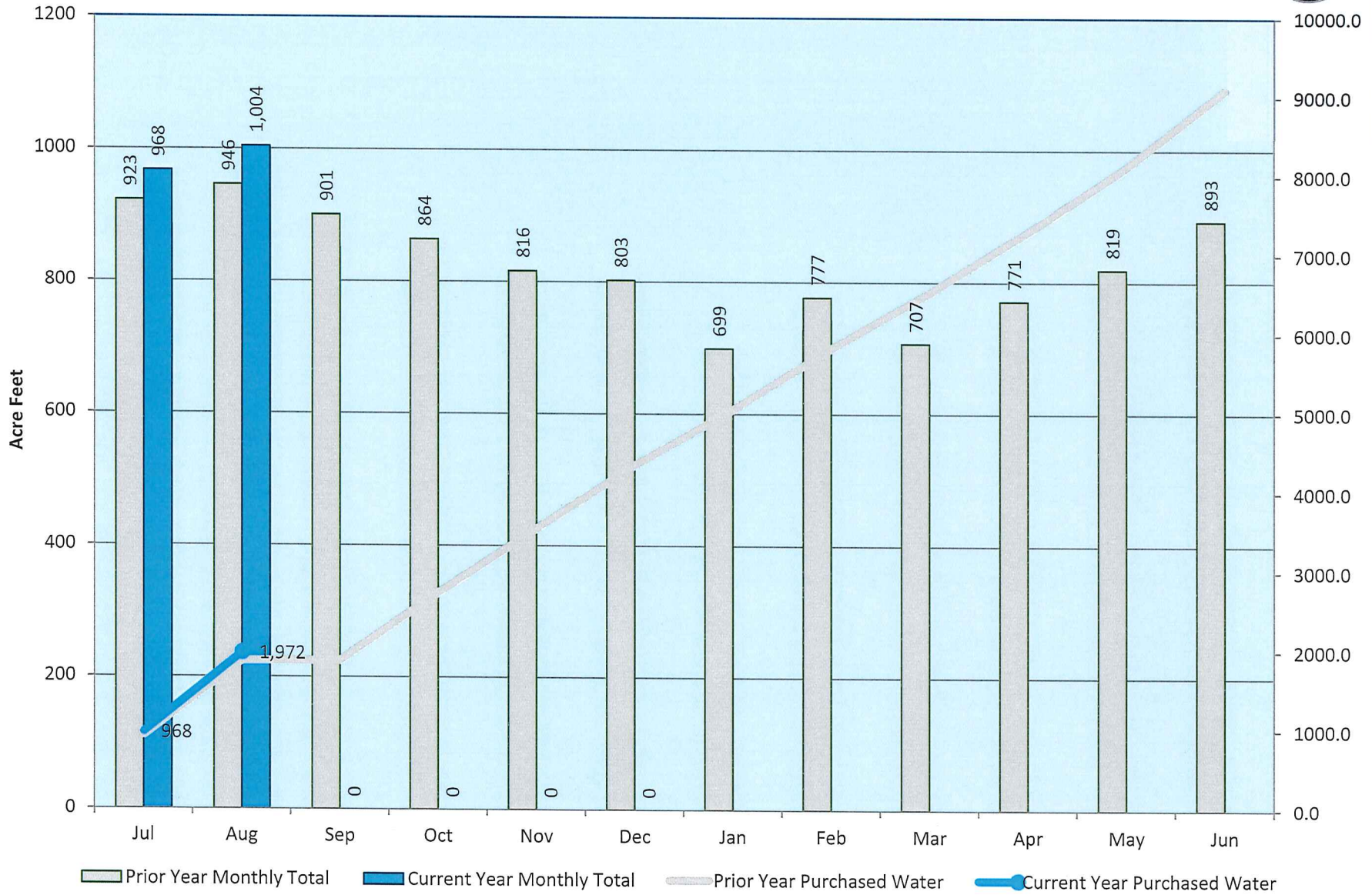

Tab

2.1



SEPTEMBER 2016-DIRECTOR REIMBURSEMENTS

Director	Date of Meeting/Event	Meeting/Event Attended	Reimbursement	No Charge	Additional Comments <i>(Submit expense report if claiming mileage and/or meal reimbursement)</i>
Anthony J. Lima					
	9/6/2016	PBWA Meeting at RWD	\$110.00		
	9/7/2016	Three Valleys Board Meeting	\$110.00		Mileage
	9/13/2016	RWD Board Meeting	\$110.00		
	9/21/2016	Three Valleys Board Meeting	\$110.00		Mileage
	9/27/2016	RWD Special Board Meeting	\$110.00		
	9/28/2016	Presidents Dinner with Dr. Rita	\$110.00		
	9/29/2016	Project Ad-Hoc Committee meeting	\$110.00		
		TOTAL PAYMENT	\$770.00		
John Bellah					
	9/12/2016	SGV Chamber Gov Affairs	\$80.00		
	9/13/2016	RWD Board Meeting	\$80.00		
	9/27/2016	RWD Special Board Meeting	\$80.00		
	9/28/2016	Presidents Dinner with Dr. Rita	\$80.00		
		TOTAL PAYMENT	\$320.00		
Robert W. Lewis					
	9/1/2016	SGV Legislative Luncheon	(\$110.00)		Correction from August
	9/6/2016	PBWA Meeting at RWD	\$110.00		
	9/12/2016	SGV Chamber Gov Affairs	\$110.00		
	9/13/2016	RWD Board Meeting	\$110.00		
	9/16/2016	ACE Fullerton Road Ground breaking		X	
	9/27/2016	RWD Special Board Meeting	\$110.00		
	9/28/2016	Presidents Dinner with Dr. Rita	\$110.00		
		TOTAL PAYMENT	\$440.00		
Szu-Pei Lu					
	9/13/2016	RWD Board Meeting	\$110.00		
	9/27/2016	RWD Special Board Meeting	\$110.00		
	9/28/2016	Presidents Dinner with Dr. Rita	\$110.00		
	9/29/2016	Project Ad-Hoc Committee meeting	\$110.00		
		TOTAL PAYMENT	\$440.00		
Teresa Rios					
	9/13/2016	RWD Board Meeting	\$110.00		
	9/27/2016	RWD Special Board Meeting	\$110.00		
	9/28/2016	Presidents Dinner with Dr. Rita	\$110.00		
		TOTAL PAYMENT	\$330.00		

APPROVED FOR PAYMENT:

Tom Coleman

Tab

2.2



BOARD OF DIRECTORS

Chairman
Ron Chong
Fluor Corp (retired)

Vice-Chairman
Roger Huynh
Caustics Digital

Secretary
Victor Wu
CPA

Treasurer
Phillip Teders
US Bancorp

Board Members

Scott Bevans
Quemetco

John Kirkham
Disney Stores

William Lundberg
Amgen Corp

Piyusha Perera
Kaiser Foundation

Thaminda Ramanayake
Amgen Corp

Derek Rojas
Valley Vista Services

Victoria Soong
Registered Nurse

Phyllis Vandeventer
Alverno High School

September 6, 2016

Board of Directors
Rowland Water District
3021 S Fullerton Road
Rowland Heights, CA 91748

Dear Rowland Water District Board,

We are requesting \$2,600 in funds to continue our Fifth Grade Water Education Program for schools in the Rowland Water Service Area this fall.

For the 2015-2016 school year, programs were given to 353 students at Bixby, Rowland, Blandford, Telesis, and Rorimer schools. The program is also partially funded by the Sanitation District of Los Angeles County.

We are looking forward to your continued support for the 2016-2017 school year.

Yours truly,

Ron Chong, Chairman

cc: Tom Coleman,  Brittnie Van de Car

Tab

2.3

RECORDING REQUESTED BY
AND WHEN RECORDED MAIL TO:

ROWLAND WATER DISTRICT
3021 South Fullerton Road
Rowland Heights, California 91748

(Space above this line for Recorder's Use Only)

MAIL TAX STATEMENTS TO:

ROWLAND WATER DISTRICT
3021 South Fullerton Road
Rowland Heights, California 91748

Documentary Transfer Tax \$ None
Exempt per Rev. & Tax Code 11922

EASEMENT GRANT DEED

FOR A VALUABLE CONSIDERATION, receipt of which is hereby acknowledged, KRAUSZ PUENTE THREE, LLC, a Delaware limited liability company, ("Grantor") hereby grants to ROWLAND WATER DISTRICT, a County Water District of the State of California ("Grantee"), its successors and assigns, an easement and right of way to construct, use, maintain, operate, alter, add to, repair, replace, reconstruct, enlarge, improve, inspect, relocate (but only within the easement area) and remove, at any time and from time to time, underground water pipelines and mains (hereinafter referred to as "systems") consisting of pipes, valves, vaults, meters, air appurtenances thereto, both above ground and underground, for the purpose of transmitting, conveying and distributing water in, on, over, under, across, and along that certain real property in the County of Los Angeles, State of California, described in Exhibit "A" and shown on Exhibit "B: attached hereto and incorporated herein.

Grantor agrees that it and its successors and assigns will not erect, place or maintain, nor permit the erection, placement, or maintenance of any building, wall, sign, light standard or other structure, nor increase the earth fill above said systems to a depth of more than four (4) feet or remove the earth fill to a depth of less than three (3) feet nor plant any trees on the above described real property. The Grantee and its contractors, agents, and employees shall have the right to trim or cut tree roots which may endanger or interfere with said systems and shall have free access to said systems and every part thereof, at all times for the purpose of exercising the rights herein granted; provided however, that in making any excavation on said property, the Grantee shall make the same in such manner as will cause the least injury to the surface of the ground around such excavation, and shall replace the earth so removed by it and restore existing asphalt pavement to as near the same condition as it was prior to such excavation as is practicable.

Except as to the rights granted herein, the Grantor shall continue to have the full use, occupancy and enjoyment of said real property. In the event that the Grantee's systems located on the foregoing described easement shall not be used for a continuous period of one (1) year, Grantor shall give ninety (90) days written notice of possible termination of the easement. If after the expiration of 90 days from written notice the subject property remains without use, then the rights hereby granted shall terminate. Upon written notice by Grantor to Grantee, and termination, the Grantee agrees to remove all of its systems from the foregoing described property or seal or cap and abandon in place such systems (in full compliance with all applicable laws and ordinances), at its own expense, and to furnish Grantor with quitclaim deeds in recordable form, for all rights, title, and interest in the foregoing described easement.

Executed this 12th day of August, 2016.

LANDLORD:

KRAUSZ PUENTE THREE, LLC,
a Delaware limited liability company

By: KRAUSZ PUENTE, LLC,
a California limited liability company
its Sole Member

By: KRAUSZ CAPISTRANO PARTNERS,
a California general partnership
a Member

By: KRAUSZ DEVELOPMENT PARTNERS,
a California general partnership
a General Partner

By: KRAUSZ MANAGEMENT ONE, LLC,
a Delaware limited liability company
a Managing Partner

By: 
F. Ron Krausz, Managing Member

By: KRAUSZ ENTERPRISES,
a California general partnership
a General Partner

By: 
F. Ron Krausz, General Partner

CALIFORNIA CERTIFICATE OF ACKNOWLEDGMENT

A notary public or other officer completing this certificate verifies only the identity of the individual who signed the document to which this certificate is attached, and not the truthfulness, accuracy, or validity of that document.

State of California)

County of Napa)

On August 12 before me, MARTHA A. Muleady,
(here insert name and title of the officer)

personally appeared F. Row Krausz

who proved to me on the basis of satisfactory evidence to be the person(s) whose name(s) is/are subscribed to the within instrument and acknowledged to me that he/she/they executed the same in his/her/their authorized capacity(ies), and that by his/her/their signature(s) on the instrument the person(s), or the entity upon behalf of which the person(s) acted, executed the instrument.

I certify under PENALTY OF PERJURY under the laws of the State of California that the foregoing paragraph is true and correct.

WITNESS my hand and official seal.

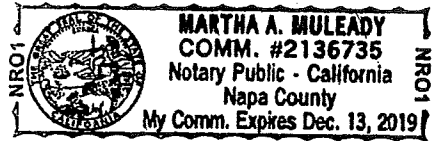

Signature Martha A. Muleady

(Seal)

Optional Information

Although the information in this section is not required by law, it could prevent fraudulent removal and reattachment of this acknowledgment to an unauthorized document and may prove useful to persons relying on the attached document.

Description of Attached Document

The preceding Certificate of Acknowledgment is attached to a document titled/for the purpose of Easement Grant Deed

containing 2 pages, and dated August 12, 2016.

The signer(s) capacity or authority is/are as:

- Individual(s)
 Attorney-in-Fact
 Corporate Officer(s) _____
Title(s) _____
- Guardian/Conservator
 Partner - Limited/General
 Trustee(s)
 Other: _____

representing: _____
Name(s) of Person(s) or Entity(ies) Signer is Representing

Additional Information

Method of Signer Identification

Proved to me on the basis of satisfactory evidence:

- form(s) of identification credible witness(es)

Notarial event is detailed in notary journal on:

Page # _____ Entry # _____

Notary contact: _____

Other

Additional Signer(s) Signer(s) Thumbprint(s)

CITY OF INDUSTRY
WATER LINE EASEMENT
(LEGAL DESCRIPTION)

THOSE PORTIONS OF PARCELS 1 AND 2 OF PARCEL MAP NO. 322, IN THE CITY OF INDUSTRY, COUNTY OF LOS ANGELES, STATE OF CALIFORNIA, AS PER MAP FILED IN BOOK 315, PAGES 37 THROUGH 44, INCLUSIVE OF PARCEL MAPS, IN THE OFFICE OF THE COUNTY RECORDER OF SAID COUNTY, DESCRIBED AS FOLLOWS:

BEGINNING AT THE MOST NORTHEASTERLY CORNER OF SAID PARCEL 1; THENCE, ALONG THE NORTHERLY LINE OF SAID PARCEL 1, NORTH 83°59'23" WEST 22.62 FEET TO THE **TRUE POINT OF BEGINNING** OF THIS DESCRIPTION;

THENCE, SOUTH 05°38'34" WEST 26.78 FEET TO THE EASTERLY LINE OF SAID PARCEL 1;
THENCE, ALONG SAID EASTERLY LINE SOUTH 45°58'42" WEST 1.67 FEET;
THENCE, LEAVING SAID EASTERLY LINE NORTH 84°21'26" WEST 8.92 FEET;
THENCE, NORTH 05°38'34" EAST 24.08 FEET TO THE BEGINNING OF A NON-TANGENT CURVE CONCAVE TO THE SOUTH HAVING A RADIUS OF 525.00 FEET, A RADIAL LINE TO SAID BEGINNING BEARS NORTH 15°24'23" EAST;
THENCE, WESTERLY 86.10 FEET ALONG SAID NON-TANGENT CURVE THROUGH A CENTRAL ANGLE OF 09°23'46";
THENCE, NORTH 83°59'23" WEST 30.31 FEET;
THENCE, SOUTH 06°00'37" WEST 10.25 FEET;
THENCE, NORTH 83°59'23" WEST 21.78 FEET;
THENCE, NORTH 06°00'37" EAST 10.25 FEET;
THENCE, NORTH 83°59'23" WEST 48.17 FEET;
THENCE, NORTH 06°00'37" EAST 10.00 FEET;
THENCE, SOUTH 83°59'23" EAST 100.26 FEET TO THE BEGINNING OF A CURVE CONCAVE TO THE SOUTH HAVING A RADIUS OF 535.00 FEET;
THENCE, EASTERLY 96.18 FEET ALONG SAID CURVE THROUGH A CENTRAL ANGLE OF 10°18'00";
THENCE, SOUTH 05°38'34" WEST 4.38 FEET TO THE **TRUE POINT OF BEGINNING**;

CONTAINING AN AREA OF APPROXIMATELY 2,419 SQUARE FEET OR 0.056 ACRE.

AS SHOWN ON THE ATTACHED PAGE 2 OF 2 AND BY THIS REFERENCE MADE A PART HEREOF.

SUBJECT TO EASEMENTS, COVENANTS, CONDITIONS, RESTRICTIONS, RESERVATIONS, RIGHTS, RIGHTS-OF-WAY AND OTHER MATTERS OF RECORD, IF ANY.

LEGAL DESCRIPTION PREPARED UNDER THE SUPERVISION OF:

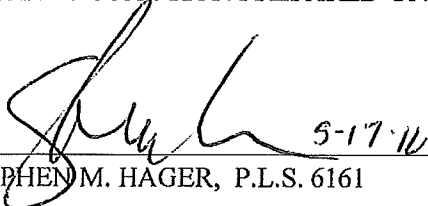
STEPHEN M. HAGER, P.L.S. 6161



AZUSA AVENUE

NOT TO SCALE

PARCEL 2
PARCEL MAP NO. 322
P.M.B. 315/37-44

PARCEL 1
PARCEL MAP NO. 322
P.M.B. 315/37-44

PARCEL 3
PARCEL MAP NO. 27-A
P.M.B. 42/61-64

LINE DATA TABLE

LINE	BEARING	DISTANCE
L1	S05°38'34"W	26.78'
L2	S45°58'42"W	1.67'
L3	N84°21'26"W	8.92'
L4	N05°38'34"E	24.08'
L5	N83°59'23"W	30.31'
L6	S06°00'37"W	10.25'
L7	N83°59'23"W	21.78'
L8	N06°00'37"E	10.25'
L9	N83°59'23"W	48.17'
L10	N06°00'37"E	10.00'
L11	S05°38'34"W	4.38'
L12	N83°59'23"W	22.62'

CURVE DATA TABLE

CURVE	DELTA	RADIUS	LENGTH
C1	09°23'46"	525.00'	86.10'
C2	10°18'00"	535.00'	96.18'

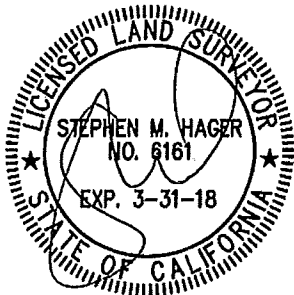

BASIS OF BEARINGS:

THE BEARING N05°34'18"E FOR THE CENTERLINE OF AZUSA AVENUE AS SHOWN ON PARCEL MAP NO. 322, FILED IN BOOK 315, PAGES 37 THROUGH 44, INCLUSIVE OF PARCEL MAPS, RECORDS OF LOS ANGELES COUNTY, STATE OF CALIFORNIA, WAS USED AS THE BASIS OF BEARINGS FOR THIS EXHIBIT.

NOTE:

AS DESCRIBED ON THE ATTACHED PAGE 1 OF 2 AND BY THIS REFERENCE MADE A PART THEREOF.

NOTES:

- (A) MOST NORTHEASTERLY CORNER OF PARCEL 1 OF PARCEL MAP NO. 322, P.M.B. 315, PAGES 37 THROUGH 44, INCLUSIVE OF PARCEL MAPS.
- (B) NORTHERLY LINE OF PARCEL 1 OF PARCEL MAP NO. 322, P.M.B. 315, PAGE 37 THROUGH 44, INCLUSIVE OF PARCEL MAPS.
- (C) EASTERLY LINE OF PARCEL 1 OF PARCEL MAP NO. 322, P.M.B. 315, PAGE 37 THROUGH 44, INCLUSIVE OF PARCEL MAPS.



INDICATES AREA OF WATER EASEMENT

EASEMENT AREA: 2,419 SQUARE FEET

Prepared by:

Joseph C. Truxaw and Associates, Inc.

Civil Engineers and Land Surveyors

265 S. Anillo Drive, Suite 111, Orange, (714) 935-0265

www.truxaw.com

**WATER LINE EASEMENT
IN THE CITY OF INDUSTRY**

DRAWN: CL

CHKD: SMH

DATE: 5-17-16

DATE: 5-17-16

PAGE 2 OF 2

I:\CFAI\2061\12061 water easement.dwg, Layout1, 5/17/2016 8:23:46 AM

Joseph C. Truxaw & Associates

Closure Report

Project: cfa12061

Description: cfa12061-city of industry

Traverse of: water easement

Bearing	Distance	Northing	Easting
	Starting at	1918.0844	927.1878
S 05 38 34 W	26.78' to	1891.4341	924.5546
S 45 58 42 W	1.67' to	1890.2736	923.3537
N 84 21 26 W	8.92' to	1891.1507	914.4770
N 05 38 34 E	24.08' to	1915.1140	916.8446
S 15 24 23 W (R)	525.00' to	1408.9794	777.3712
Delta = 09 23 46 Radius = 525.00' Length = 86.10' Chord = N 79 17 30 W 86.00' Tangent = 43.14'			
N 06 00 37 E (R)	525.00' to	1931.0936	832.3423
N 83 59 23 W	30.31' to	1934.2673	802.1989
S 06 00 37 W	10.25' to	1924.0736	801.1256
N 83 59 23 W	21.78' to	1926.3541	779.4654
N 06 00 37 E	10.25' to	1936.5478	780.5386
N 83 59 23 W	48.17' to	1941.5915	732.6334
N 06 00 37 E	10.00' to	1951.5365	733.6804
S 83 59 23 E	100.26' to	1941.0386	833.3893
S 06 00 37 W (R)	535.00' to	1408.9795	777.3712
Delta = 10 18 00 Radius = 535.00' Length = 96.18' Chord = S 78 50 23 E 96.05' Tangent = 48.22'			
N 16 18 37 E (R)	535.00' to	1922.4478	927.6230
S 05 38 34 W	4.38' to	1918.0890	927.1923

Error of closure North = 0.00460884 East = 0.00456314
Bearing S 44 42 52 W Distance = 0.0065
Area = 2,419.17 SF 0.056 Acres
Perimeter = 479.13' Precision = 1 : 73875

Total Area of the Lots: 2,419.17 SF 0.056 Acres

Tab

2.4

RECORDATION REQUESTED BY
AND WHEN RECORDED MAIL TO:

ROWLAND WATER DISTRICT
3021 Fullerton Road
Rowland Heights, CA 91748

Free Recording Requested Under Government Code
Section 6103, Document Necessary Due to City Interest

This is a bonafide gift and the grantor received nothing in
return, R & T 11911

QUITCLAIM DEED

For valuable consideration, receipt of which is hereby acknowledged, the **ROWLAND WATER DISTRICT**, a county water district ("Grantor"), hereby quitclaims and releases to **KRAUSZ PUENTE THREE, LLC**, a Delaware limited liability company ("Grantee"), all of its rights and interests in and to that certain real property located in the City of Industry, County of Los Angeles, State of California, as described on the attached Exhibit "A" (the "Property"), including, without limitation, the following: (i) its right to install, construct, reconstruct, remove and replace, inspect, maintain, operate, repair and improve an underground water transmission line with incidental appurtenances on, in or under the Property pursuant to that certain Easement Grant Deed for Water Transmission and Access Purposes, recorded on January 29, 1998 in the Official Records of the County Recorder of Los Angeles County as Instrument No. 98-152506, and (ii) in connection with any public right-of-way improvements covering or encroaching upon the Property.

Dated: _____, 2016

ROWLAND WATER DISTRICT

By _____
TOM COLEMAN
GENERAL MANAGER

ACKNOWLEDGMENT

STATE OF CALIFORNIA)
)
COUNTY OF LOS ANGELES)

On _____, before me, ROSEMARIE PEREA, Notary Public, personally appeared TOM COLEMAN, personally known to me (or proved to me on the basis of satisfactory evidence) to be the person whose name is subscribed to the within instrument and acknowledged to me that he executed the same in his authorized capacity, and that by his signature on the instrument the person, or the entity upon behalf of which the person acted, executed the instrument.

I certify under PENALTY OF PERJURY under the laws of the State of California that the foregoing is true and correct.

WITNESS my hand and official seal.

Signature _____
(Signature of Notary Public)

(Seal)

CITY OF INDUSTRY
QUITCLAIM OF WATER LINE EASEMENT
(LEGAL DESCRIPTION)

THAT PORTION OF A 10 FOOT WIDE EASEMENT GRANTED TO ROWLAND WATER DISTRICT, A COUNTY WATER DISTRICT, AS RECORDED JANUARY 29, 1998, AS INSTRUMENT NO. 98-152506, OFFICIAL RECORDS, LYING WITHIN PARCEL 1 OF PARCEL MAP NO. 322, IN THE CITY OF INDUSTRY, COUNTY OF LOS ANGELES, STATE OF CALIFORNIA, AS PER MAP FILED IN BOOK 315, PAGES 37 THROUGH 44, INCLUSIVE OF PARCEL MAPS, IN THE OFFICE OF THE COUNTY RECORDER OF SAID COUNTY.

BEGINNING AT THE MOST NORTHEASTERLY CORNER OF PARCEL 1 OF SAID PARCEL MAP; THENCE, ALONG THE EASTERLY LINE OF SAID PARCEL SOUTH 45°58'42" WEST 20.63 FEET TO A POINT DESIGNATED AS POINT 'A' AND THE TRUE POINT OF BEGINNING OF THIS DESCRIPTION;

THENCE, CONTINUING SOUTH 45°58'42" WEST 13.05 FEET TO THE SOUTHERLY LINE OF SAID 10 FOOT WIDE EASEMENT;
THENCE, ALONG SAID SOUTHERLY LINE NORTH 84°01'19" WEST 240.05 FEET TO THE WESTERLY LINE OF SAID PARCEL 1;
THENCE, ALONG SAID WESTERLY LINE NORTH 18°22'11" EAST 10.24 FEET TO THE NORTHERLY LINE OF SAID EASEMENT;
THENCE, ALONG SAID NORTHERLY LINE SOUTH 84°01'19" EAST 237.80 FEET TO THE TRUE POINT OF BEGINNING.

EXCEPTING THEREFROM THAT PORTION DESCRIBED AS FOLLOWS:

BEGINNING AT POINT 'A' AS DESIGNATED HEREIN; THENCE, SOUTH 45°58'42" WEST 13.05 FEET TO THE SOUTHERLY LINE OF SAID EASEMENT;
THENCE, ALONG SAID SOUTHERLY LINE NORTH 84°01'19" WEST 0.82 FEET;
THENCE, LEAVING SAID SOUTHERLY LINE NORTH 05°38'34" EAST 10.00 FEET TO THE NORTHERLY LINE OF SAID EASEMENT;
THENCE, ALONG SAID NORTHERLY LINE SOUTH 84°01'19" EAST 9.27 FEET TO THE TRUE POINT OF BEGINNING.

CONTAINING AN AREA OF APPROXIMATELY 2,389 SQUARE FEET OR 0.055 ACRE.

AS SHOWN ON THE ATTACHED PAGE 2 OF 2 AND BY THIS REFERENCE MADE A PART HEREOF.

SUBJECT TO EASEMENTS, COVENANTS, CONDITIONS, RESTRICTIONS, RESERVATIONS, RIGHTS, RIGHTS-OF-WAY AND OTHER MATTERS OF RECORD, IF ANY.

LEGAL DESCRIPTION PREPARED UNDER THE SUPERVISION OF:

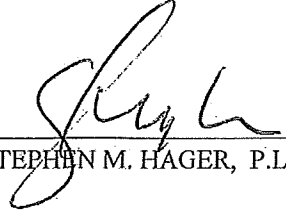
5-17-16
STEPHEN M. HAGER, P.L.S. 6161



PARCEL 2
 PARCEL MAP NO. 322
 P.M.B. 315/37-44

PARCEL 1
 PARCEL MAP NO. 322
 P.M.B. 315/37-44

PARCEL 3
 PARCEL MAP NO. 27-A
 P.M.B. 42/61-64

LINE DATA TABLE

LINE	BEARING	DISTANCE
L1	N18°22'11"E	10.24'
L2	S05°38'34"W	10.00'

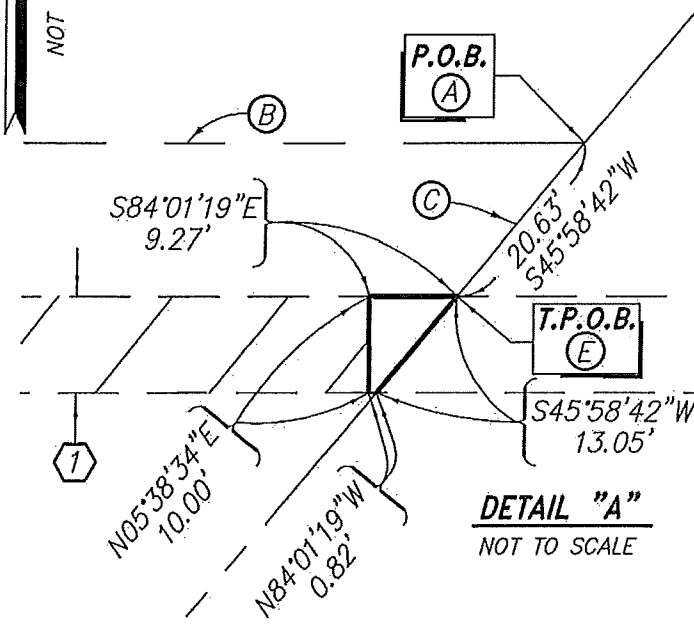
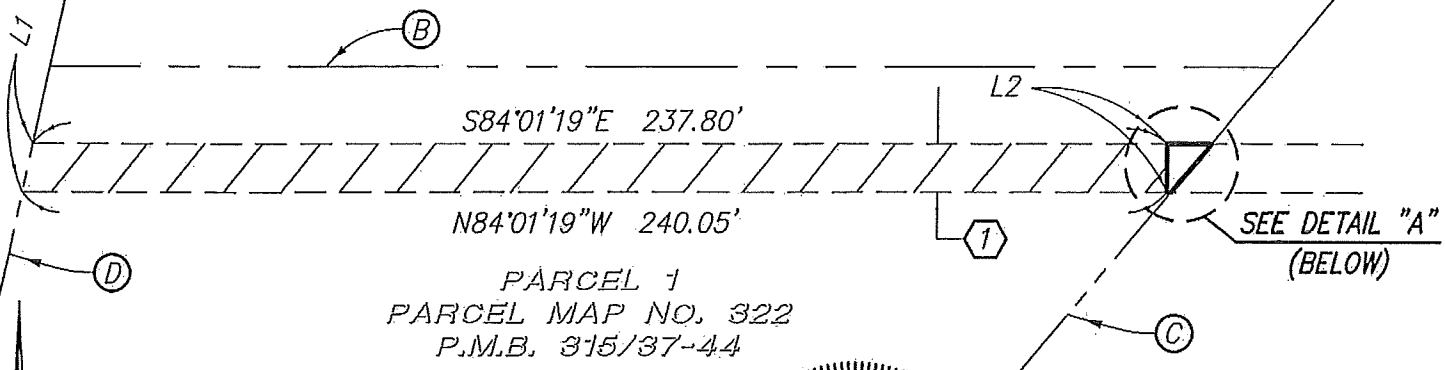
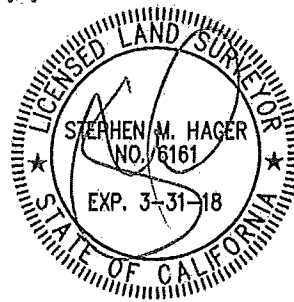

- NOTES:**
- (A) MOST NORTHEASTERLY CORNER OF PARCEL 1 OF PARCEL MAP NO. 322, P.M.B. 315, PAGES 37 THROUGH 44, INCLUSIVE OF PARCEL MAPS.
 - (B) NORTHERLY LINE OF PARCEL 1 OF PARCEL MAP NO. 322, P.M.B. 315, PAGE 37 THROUGH 44, INCLUSIVE OF PARCEL MAPS.
 - (C) EASTERLY LINE OF PARCEL 1 OF PARCEL MAP NO. 322, P.M.B. 315, PAGE 37 THROUGH 44, INCLUSIVE OF PARCEL MAPS.
 - (D) WESTERLY LINE OF PARCEL 1 OF PARCEL MAP NO. 322, P.M.B. 315, PAGE 37 THROUGH 44, INCLUSIVE OF PARCEL MAPS.
 - (E) POINT 'A'
 - (1) 10' WIDE EASEMENT GRANTED TO ROWLAND WATER DISTRICT, RECORDED JANUARY 29, 1998 AS INSTRUMENT NO. 98-152506, O.R.

BASIS OF BEARINGS:

THE BEARING N05°34'18"E FOR THE CENTERLINE OF AZUSA AVENUE AS SHOWN ON PARCEL MAP NO. 322, FILED IN BOOK 315, PAGES 37 THROUGH 44, INCLUSIVE OF PARCEL MAPS, RECORDS OF LOS ANGELES COUNTY, STATE OF CALIFORNIA, WAS USED AS THE BASIS OF BEARINGS FOR THIS EXHIBIT.

NOTE:

AS DESCRIBED ON THE ATTACHED PAGE 1 OF 2 AND BY THIS REFERENCE MADE A PART THEREOF.

INDICATES AREA OF QUITCLAIM

EASEMENT AREA: 2,389 SQUARE FEET

Prepared by:
 Joseph C. Truxaw and Associates, Inc.
 Civil Engineers and Land Surveyors
 265 S. Anillo Drive, Suite 111, Orange, (714) 935-0285
 www.truxaw.com

QUITCLAIM OF WATER LINE EASEMENT IN THE CITY OF INDUSTRY			
DRAWN: CL	CHKD: SMH		PAGE 2 OF 2
DATE: 5-17-16	DATE: 5-17-16		

G:\CFTA\12061\12061 water quitclaim.dwg. Layout1. 5/17/2016 8:26:08 AM

Joseph C. Truxaw & Associates

Closure Report

Project: cfa12061

Description: cfa12061-city of industry

Traverse of: water line quitclaim easement

Bearing	Distance	Northing	Easting
	Starting at	1892.3957	924.6496
N 84 01 19 W	240.05' to	1917.3963	685.9050
N 18 22 11 E	10.24' to	1927.1145	689.1321
S 84 01 19 E	237.80' to	1902.3482	925.6389
S 05 38 34 W	10.00' to	1892.3966	924.6557

Error of closure North = 0.00098640 East = 0.00608764
Bearing S 80 47 46 W Distance = 0.0062
Area = 2,389.26 SF 0.055 Acres
Perimeter = 498.09' Precision = 1 : 80767

Total Area of the Lots: 2,389.26 SF 0.055 Acres

Joseph C. Truxaw & Associates

Closure Report

Project: cfa12061

Description: cfa12061-city of industry

Traverse of: water line exception

Bearing	Distance	Northing	Easting
	Starting at	1901.3823	934.8487
S 45 58 42 W	13.054' to	1892.3107	925.4618
N 84 01 19 W	0.817' to	1892.3958	924.6493
N 05 38 34 E	10.000' to	1902.3473	925.6326
S 84 01 19 E	9.266' to	1901.3823	934.8482

Error of closure North = 0.00002069 East = 0.00051960
Bearing N 87 43 11 E Distance = 0.0005
Area = 50.41 SF 0.001 Acres
Perimeter = 33.137' Precision = 1 : 63724

Total Area of the Lots: 50.41 SF 0.001 Acres

Tab

2.5

WHITE NELSON DIEHL EVANS LLP
Certified Public Accountants & Consultants

September 22, 2016

Mr. Sean Henry, Finance Officer
Rowland Water District
3021 S. Fullerton Road
Rowland Heights, CA 91748

Dear Mr. Henry:

Enclosed is the "Communication with Those Charged with Governance" letter. Please forward the letter to the Board of Directors, as soon as possible.

If you have any questions, please feel free to call me.

Very truly yours,



Robert J. Callanan, CPA

To the Board of Directors
Rowland Water District
Rowland Heights, California

We are engaged to audit the financial statements of the Rowland Water District (the District) for the year ended June 30, 2016. Professional standards require that we provide you with the following information related to our audit. We would also appreciate the opportunity to meet with you to discuss this information further since a two-way dialogue can provide valuable information for the audit process.

Our Responsibility under U.S. Generally Accepted Auditing Standards and *Government Auditing Standards*

As stated in our engagement letter dated August 9, 2016, our responsibility, as described by professional standards, is to express an opinion about whether the financial statements prepared by management with your oversight are fairly presented, in all material respects, in conformity with U.S. generally accepted accounting principles. Our audit of the financial statements does not relieve you or management of your responsibilities.

As part of our audit, we will consider the internal control of the District. Such considerations are solely for the purpose of determining our audit procedures and not to provide any assurance concerning such internal control.

As part of obtaining reasonable assurance about whether the financial statements are free of material misstatement, we will also perform tests of the District's compliance with certain provisions of laws, regulations, contracts, and grants. However, providing an opinion on compliance with those provisions is not an objective of our audit.

We are responsible for communicating significant matters related to the audit that are, in our professional judgment, relevant to your responsibilities in overseeing the financial reporting process. However, we are not required to design procedures specifically to identify such matters.

Generally accepted accounting principles provide for certain required supplementary information (RSI) to supplement the basic financial statements. Our responsibility with respect to the management's discussion and analysis, schedule of funding progress for the other post-employment health benefit plan and the District's defined benefit plan schedules required by GASB Statement No. 68, Accounting and Financial Reporting for Pensions - An Amendment of GASB Statement No. 27, which supplement the basic financial statements, is to apply certain limited procedures in accordance with generally accepted auditing standards. However, the RSI will not be audited and, because the limited procedures do not provide us with sufficient evidence to express an opinion or provide any assurance, we will not express an opinion or provide any assurance on the RSI.

Our Responsibilities under U.S. Generally Accepted Auditing Standards and Government Auditing Standards (Continued)

We have been engaged to report on the Schedule of Other Operating Expenses and Schedule of General and Administrative Expenses, which accompany the financial statements but are not RSI. Our responsibility for this supplementary information, as described by professional standards, is to evaluate the presentation of the supplementary information in relation to the financial statements as a whole and to report on whether the supplementary information is fairly stated, in all material respects, in relation to the financial statements as a whole.

Planned Scope and Timing of the Audit

An audit includes examining, on a test basis, evidence supporting the amounts and disclosures in the financial statements; therefore, our audit will involve judgment about the number of transactions to be examined and the areas to be tested.

Our audit will include obtaining an understanding of the District and its environment, including internal control, sufficient to assess the risks of material misstatement of the financial statements and to design the nature, timing, and extent of further audit procedures. Material misstatements may result from (1) errors, (2) fraudulent financial reporting, (3) misappropriation of assets, or (4) violations of laws or governmental regulations that are attributable to the District or to acts by management or employees acting on behalf of the District. We will generally communicate our significant findings at the conclusion of the audit. However, some matters could be communicated sooner, particularly if significant difficulties are encountered during the audit where assistance is needed to overcome the difficulties or if the difficulties may lead to a modified opinion. We will also communicate any internal control related matters that are required to be communicated under professional standards. If a member of the Board is aware of matters that have a material bearing on the financial statements taken as a whole (such as those described above in items 1-4), please contact Mr. Robert Callanan at (714) 978-1300 or by email at rcallanan@wndecpa.com by October 7, 2016.

We expect to issue our report by October 31, 2016.

This information is intended solely for the use of the District's Board of Directors and management of the District and is not intended to be, and should not be, used by anyone other than these specified parties.

White Nelson Dick Evans LLP

Irvine, California
September 22, 2016

Tab

2.6

**Rowland Water District
Communication Strategies Update
October 11, 2016**

- **Proposition 218 / Water Rate Study**
 - Wireframe complete
 - Incorporating narrative from rate study
 - Preparing draft notice

- **Conservation/Drought**
 - New flyer complete

- **Buckboard Days**
 - Banner, t-shirt and ads complete
 - Press release distributed

- **Additional Sponsorships**
 - For Us flyer complete

- **Additional Releases**
 - Customer Appreciation Week
 - OPARC Award
 - Santana High School/Solar Cup

- **District Video**
 - Concepts under consideration

- **Miscellaneous**
 - Educational brochure (additional changes)
 - Website (sliders and text updated as needed)
 - On-Hold Messages

• Press Releases

Date	News Story	In Process	Completed	Distributed
1/21/16	El Nino Preparations	*****	*****	*****
2/29/16	OPARC Program	*****	*****	*****
3/1/16	Learning Center MOU/Interns	*****	*****	
3/1/16	Audit Review and Completion	*****	*****	*****
3/31/16	ACWA/JPIA Refund	*****	*****	*****
6/1/16	Certificate of Excellence	*****	*****	*****
6/1/16	Solar Cup	*****	*****	*****
6/27/16	CCR Availability	*****	*****	*****
7/6/16	Urban Water Management	*****	*****	*****
7/9/16	Poster Contest	*****	*****	*****
7/27/16	Level 1 Water Supply	*****	*****	*****
7/31/16	Annual Budget	*****	*****	*****
8/2/16	Conflict of Interest	*****	*****	*****
9/22/16	Water Rates	*****		
9/30/16	Customer Appreciation Week	*****	*****	*****
10/1/16	Santana/Solar Cup	*****	*****	
10/6/16	OPARC Event	*****	*****	*****



Memorandum

To: Board of Directors

From: Brittnie Van De Car
Public Affairs Representative

Date: October 11, 2016

Re: Public Affairs & Education Update

- Upcoming Classroom Presentations
 - November 1, 2016
 - Blandford Elementary School
 - 3rd Grade
 - 3 Presentations
 - Water Conservation Jeopardy Activity
 - **72 Students Total**
 - November 2, 2016
 - Blandford Elementary School
 - 3rd Grade
 - 2 Presentations
 - Water Conservation Jeopardy Activity
 - **48 Students Total**
 - November 8, 2016
 - Rowland Elementary School
 - 2nd Grade
 - 2 Presentations
 - Water Cycle Bracelet
 - **52 Students Total**
 - November 9, 2016
 - Rowland Elementary School
 - 2nd Grade
 - 1 Presentation
 - Water Cycle Presentation
 - **26 Students Total**
 - **198 Students Reached**
- Preparing for the Buckboard Days Parade
- Handed out over 300 giveaways for Customer Service Appreciation week
- Developing new curriculum gearing towards 3rd and 4th graders to go into effect for the next school year
- Holding a landscape class November 9th. Marketing this in the lobby
- Created a Survey Monkey to send out to the teachers that have participated in the classroom presentations.
 - The Teacher Evaluations are anonymous and provide valuable feedback
 - The feedback is used to develop and enhance future presentations



- Keeping up-to-date with the WaterSense partnership program:
 - Printing appropriate promotional material and placing it at the Customer Service Counter for distribution to customers
- Attending bi-monthly webinars on upcoming promotional items and programs put on by the Environmental Protection Agency (EPA) WaterSense program
- Updating the Lobby Player on a daily/weekly basis
- Checking the Google Analytics weekly (see attached data charts)
 - The “Website Visits and Pageviews” allows us to determine the number of **new** vs. **returning** visitors and the **source** of viewing
- The “Pageviews” allows us to evaluate which pages on the website are viewed most frequently
- Adding all new customer emails to Constant Contact to be utilized as a customer newsletter database
- Creating content, ideas and layout for quarterly e-newsletter
- Checking the District’s FaceBook and Twitter page weekly
 - Posting necessary information on the pages
- Maintain and view District website on a daily basis
 - Update pages
 - Make relevant changes
 - Updating the Drought Monitor page weekly
 - Upload the Board packet, minutes and agendas when necessary

- Attended the Metropolitan Water District Education meeting on Thursday, September 22, 2016

October 2016 Google Analytics

Website Visits and Pageviews

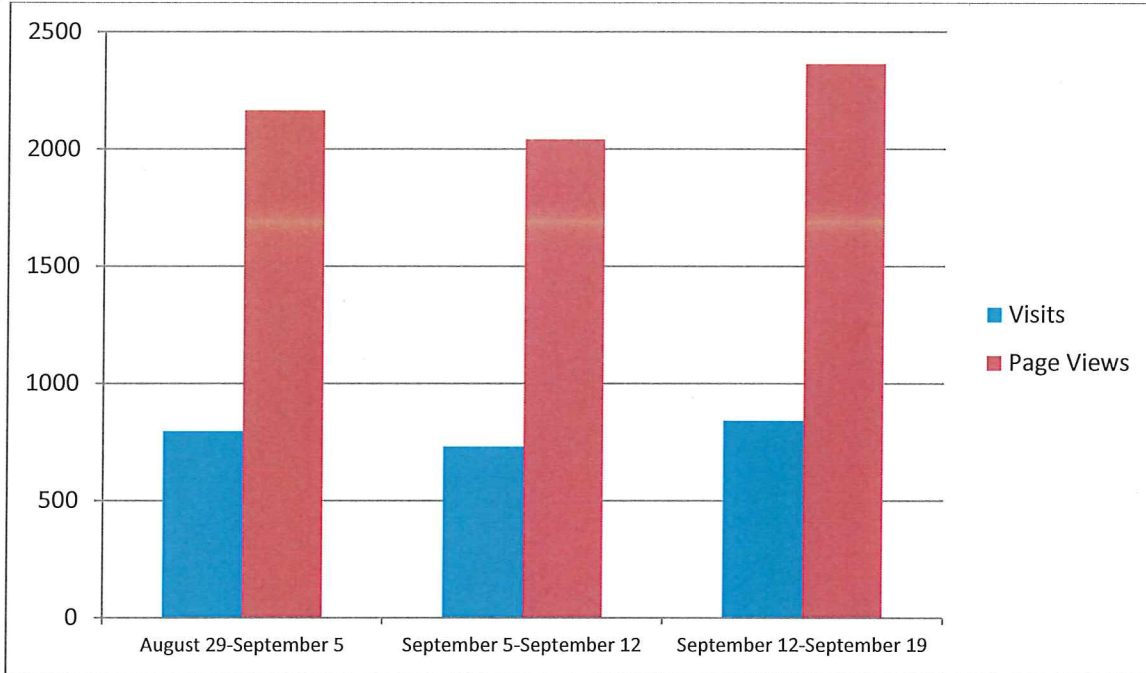

New vs. Returning Visitors

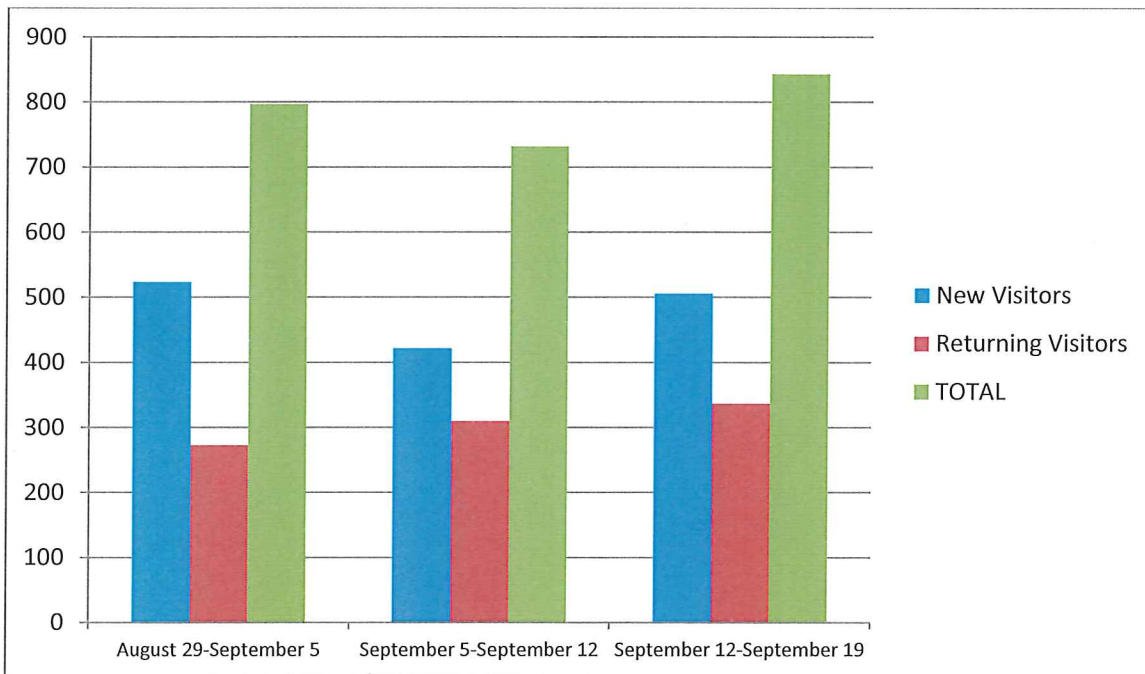

Source of Viewing

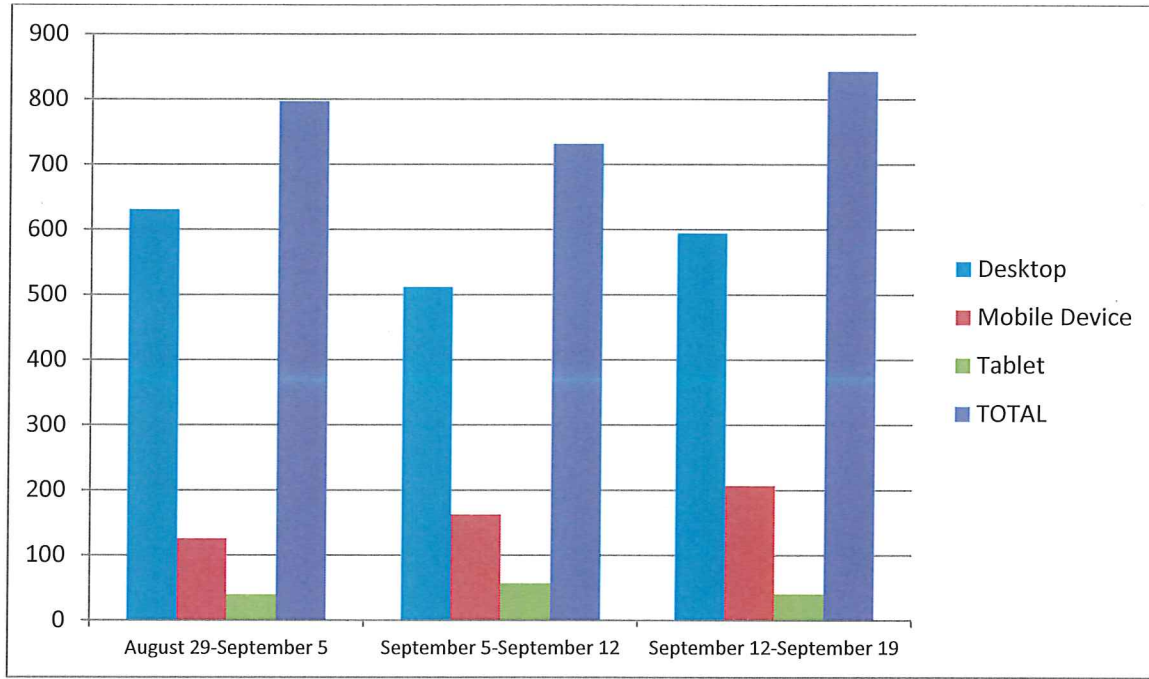

Tab

2.7

**Intentionally
Left Blank**

Tab

3.1

**Intentionally
Left Blank**

Tab

4

**Intentionally
Left Blank**

Tab

5.1

As a matter of proper business decorum, the Board of Directors respectfully request that all cell phones be turned off or placed on vibrate. Also to prevent any potential distraction of the proceeding, we request that side conversations be taken outside of the meeting room.

**AGENDA
REGULAR BOARD MEETING
THREE VALLEYS MUNICIPAL WATER DISTRICT**

Wednesday, September 21, 2016 at 8:00 AM

The mission of Three Valleys Municipal Water District is to supplement and enhance local water supplies to meet our region's needs in a reliable and cost-effective manner.

Item 1 – Call to Order

Kuhn

Item 2 – Pledge of Allegiance

Kuhn

Item 3 – Roll Call

**Executive
Assistant**

- Bob Kuhn, President, Division IV
- David De Jesus, Vice President, Division II
- Brian Bowcock, Secretary, Division III
- Joe Ruzicka, Treasurer, Division V
- Dan Horan, Director, Division VII
- Carlos Goytia, Director, Division I
- Fred Lantz, Director, Division VI

Item 4 – Additions to Agenda *(Government Code Section 54954.2(b)(2))*

Kuhn

Upon a determination by a two-thirds vote of the members of the Board present at the meeting, or, if less than two-thirds of the Board are present, a unanimous vote of the Board present, that there is a need to take immediate action, and that the need for action came to the attention of TVMWD subsequent to the agenda being posted. *The Board shall call for public comment prior to voting to add any item to the agenda after posting.*

Item 5 – Reorder Agenda

Kuhn

Item 6 Public Comment *(Government Code Section 54954.3)*

Kuhn

Opportunity for members of the public to directly address the Board on items of public interest that is within the subject matter jurisdiction of TVMWD. The public may also address the Board on items being considered on this agenda. TVMWD requests that all public speakers complete a speaker's card and provide it to the Executive Assistant.

We request that remarks be limited to five minutes or less.

The Board is being asked to consider the consent calendar items 7.1 – 7.8 listed below. Consent calendar items are routine in nature and may be considered and approved by a single motion. Any member of the Board may request that a specific item be pulled from the consent calendar for further discussion.

7.1 – Receive, Approve and File Minutes – June 2016 [enc]

- June 1, 2016 – Regular Board Meeting
- June 15, 2016 – Regular Board Meeting

7.2 – Ratify June and July 2016 Financial Reports – [enc]

- Warrant Summary Disbursements – June 2016
- Warrant Summary Disbursements – July 2016

7.3 – Approve Financial Reports and Investment Update – August 2016 [enc]

- Change in Cash and Cash Equivalents Reports
- Consolidated Listing of Investment Portfolio and Investment Report
- YTD District Budget Monthly Status Reports
- Warrant Summary Disbursements

7.4 – Resolution No. 16-09-783 Participation in the Great California Shakeout [enc]

The Board will consider approval of Resolution No. 16-09-783 to participate in the Great California Shakeout on October 20, 2016.

7.5 – Resolution No. 16-09-784 Appointment in Lieu of Election [enc]

The Board will consider approval of Resolution No. 16-09-784 authorizing appointment in lieu of election of incumbent Directors, David De Jesus, Division 2; Bob Kuhn, Division 4; and Danny M. Horan, Division 7. As of the close of the nomination period on August 12, 2016 the incumbent candidates were unchallenged. The Board will provide staff with direction to file same with the Los Angeles County Board of Supervisors and Los Angeles County Registrar Recorder/County Clerk for action.

7.6 – Resolution No. 16-09-785 Opposition to Proposition 53, “Cortopassi Initiative” [enc]

The Board will consider approval of Resolution No. 16-09-785 opposing Proposition 53, “Cortopassi Initiative” that is proposed to be included on the November 8, 2016 ballot.

7.7 – Resolution No. 16-09-786 Annual Investment Policy Updates[enc]

The Board will consider approval of Resolution No. 16-09-786 approving recommended updates to the Investment Policy and repealing any previous Resolutions concerning same.

7.8 – Approval of Verizon Cell Tower Lease [enc]

The Board will consider approval of the lease contract between TVMWD and Verizon to place a cell tower on TVMWD property and may direct the General Manager to execute same.

Items 7.1 – 7.8 Board Action Required – Motion No. 16-09-5098

Staff Recommendation: Approve as presented

Item 8 – General Manager’s Report

Hansen

Item 8.A – *Administration staff will provide brief updates on existing matters under their purview and will be available to respond to any questions thereof.*

8.A.1 – Legislative Update – September 2016 [enc]

The Board will be provided with an update of legislative activities occurring at state and federal levels.

8.A.2 – Ratify June and July 2016 Director Expense Reports and Approve Director Expense Forms, August 2016 [enc]

The Board will ratify previously processed Director Expense Reports for June 2016 and July 2016, and consider approval of the August 2016 Director expenses that include disclosure of per diem requests for meeting attendance, and an itemization of any expenses incurred by TVMWD.

Item 8.A.2: Board Action Required – Motion No. 16-09-5099

Staff Recommendation: None

Item 8.B – *Engineering-Operations staff will provide brief updates on existing matters under their purview and will be available to respond to any questions thereof.*

8.B.1 – Calendar Year Imported Water Purchases and Peak Flow Reports – August [enc]

The Board will review the imported water purchases and peak flow reports for the month ending August 2016.

8.B.2 – Miramar Operations Report – August 2016 [enc]

The Board will review the monthly Miramar Operations Report that includes a summary of the following reports: water quality, monthly production, monthly and year-to-date sales, hydro-generation production and operations / maintenance review.

Item 8.C – *Finance-Personnel staff will provide brief updates on existing matters under their purview and will be available to respond to any questions thereof.*

8.C.1 – Employee Health Care Costs CY 2017 [enc]

The Board will consider approval of Employee Health Care Costs for CY 2017.

Item 8.C.1: Board Action Required – Motion No. 16-09-5100

Staff Recommendation: Approve as presented

Item 9 – Directors’ / General Manager Oral Reports

The following reports are provided by Directors as it concerns activities at meetings of which they are assigned to serve as the representative or alternate of the District.

9.A – Local Agency Formation Commission	Ruzicka
9.B – Pomona Walnut Rowland Joint Water Line (PWR-JWL)	Horan
9.C – Six Basins Watermaster	Bowcock
9.D – Main San Gabriel Basin Watermaster	Bowcock
9.E – Chino Basin Watermaster	Kuhn
9.F – San Gabriel Basin Water Quality Authority	Kuhn
9.G – San Gabriel Valley Council of Governments	Goytia
9.H – Metropolitan Water District	De Jesus
9.I – Additional Board Member or Staff Reports / Comments	All

Item 10 – Closed Session

Kuhn

10.A – Conference With Real Property Negotiators

Pursuant to Government Code Section 54956.8

Property: Parcel No. 40576-01-01

District Negotiator: Richard Hansen and Steve Kennedy

Negotiating Parties: Department of Transportation

Under Negotiation: Terms and conditions

Item 11 – Report Out Of Closed Session

Kuhn

Item 12 – Future Agenda Items

Kuhn

Item 13 – Adjournment

Board adjourned to October 5, 2016 regular Board meeting at 8:00 a.m.

American Disabilities Act Compliance Statement

Government Code Section 54954.2(a)



Any request for disability-related modifications or accommodations (including auxiliary aids or services) that is sought in order to participate in the above agendized public meeting should be directed to the district's executive assistant at (909) 621-5568 at least 24 hours prior to meeting.

Agenda items received after posting

Government Code Section 54957.5

Materials related to an item on this agenda submitted after distribution of the agenda packet are available for public review at the district office located at, 1021 East Miramar Avenue, Claremont, CA, 91711. The materials will also be posted on the district's website at www.threevalleys.com.

The Three Valleys MWD board meeting packets and agendas are available for review on the district's website at www.threevalleys.com. The website is updated on Sunday preceding any regularly scheduled board meeting.



Action Line

Regular Board Meeting September 21, 2016

FOR ADDITIONAL INFORMATION: 909-621-5568

BOARD MEMBERS

CARLOS GOYTIA
DIVISION I

DAVID DE JESUS
DIVISION II

BRIAN BOWCOCK
DIVISION III

BOB KUHN
DIVISION IV

JOSEPH RUZICKA
DIVISION V

FRED LANTZ
DIVISION VI

DAN HORAN
DIVISION VII

THREE VALLEYS MWD

1021 E. Miramar Avenue
Claremont, CA 91711
909-621-5568 — Phone
909-625-5470 — Fax
www.threevalleys.com

Board meetings
are scheduled for
8:00 a.m. the first
and third
Wednesday of
each month at
1021 E. Miramar
Claremont, CA

Approved: *Motion No. 16-09-5101*, was called from the dais, for an Addition to the Agenda. General Counsel, Steve Kennedy advised that the tentative decision was received from the court to modify the Chino Basin Watermaster Safe Yield on September 20, 2016, less than 72 hours preceding today's scheduled Board meeting. Immediate action is required by the TVMWD Board as the Chino Basin Watermaster Board is scheduled to meet on Thursday, September 22, 2016; and the hearing to accept the final judgment in this matter is scheduled for Friday, September 23, 2016.

The following item will be added to the agenda under closed session for discussion: Conference with Legal Counsel, Existing Litigation, pursuant to Government Code Section 54956.9(d)(1) Chino Basin Municipal Water District v. City of Chino Case; San Bernardino County Case No. RCV51010. Public comment was requested prior to calling for the vote; there was no public comment. **Motion passed by a 7-0 unanimous vote.**

Approved: *Motion No. 16-09-5098* approving Consent Calendar items 7.1-7.8 as follows: (7.1) Receive, approve and file, June 2016 Board Meeting minutes for June 1, 2016 and June 15, 2016; (7.2) Ratify June and July 2016 Financial Reports — Warrant Summary

This summary may not include all agenda items and should not be construed as minutes of the meeting.

TVMWD is a water resources management agency that covers approximately 133 square miles and is governed by an elected Board of seven officials. The present population is about 525,000. Since its formation, the Three Valleys Municipal Water District has installed some 37,000 feet of pipeline and delivered more than 175 billion gallons of water.



Action Line

Regular Board Meeting

September 21, 2016 ~ Page 2 ~

Disbursements; (7.3) Receive, approve and file, August 2016 Financial Reports; (7.4) Approve **Resolution No. 16-09-783** Participation in the Great California Shakeout; (7.5) Approve **Resolution No. 16-09-784** Appointment in Lieu of Election, Divisions 2, 4 & 7; (7.6) Approve **Resolution No. 16-09-785** Opposition to Proposition 53 —Cortopassi Initiative; (7.7) Approve **Resolution No. 16-09-786** Annual Investment Policy Updates; (7.8) Approval of Verizon Cell Tower Lease; Mr. Kennedy alerted staff that a correction on the Verizon Cell Tower Lease Agreement under Section 4, page 2 of 20 must be made prior to executing the agreement. **Motion passed by a 7-0 unanimous vote.**

Approved: *Motion No. 16-09-5099* to ratify June and July 2016 Director Expense Reports and approval of August 2016 Director Expense Reports. **Motion passed by a 7-0 unanimous vote.**

Approved: *Motion No. 16-09-5100* approving Employee Health Care Costs for CY 2017. **Motion passed by a 7-0 unanimous vote.**

Closed Session: A closed session was convened commencing at 9:00 a.m. to discuss two items as follows:

(A) *Conference with Real Property Negotiators*, pursuant to Government Code Section 54956.8; Property: Parcel No. 40576-01-01; District Negotiator: Richard Hansen and Steve Kennedy; Negotiating Parties: Department of Transportation; Under negotiation: Terms and Conditions.

(B) *Conference with Legal Counsel, Existing Litigation*, pursuant to Government Code Section 54954.2(b)(2); Chino Basin Municipal Water District v. City of Chino Case; San Bernardino County Case No. RCV51010.

Closed Session Report:

Regular Session was reconvened at 9:45 a.m. with the following report out of Closed Session:



Action Line

Regular Board Meeting

September 21, 2016 ~ Page 3 ~

Item (A) Mr. Kennedy reported that TVMWD has acquired title to the property identified on the agenda, Parcel No. 40576-01-01 in the amount of \$17,300 from the State of California Cal Trans.

Item (B) Chino Basin Municipal Water District v. City of Chino, San Bernardino County, Case No. RCV51010 — there was no reportable action.

Upcoming Meeting Notices:

- **Wednesday, October 5, 2016—Regular Board Meeting @ 8:00 a.m.**
- **Wednesday, October 19, 2016—Regular Board Meeting @ 8:00 a.m.**
- **Thursday, October 27, 2016—Leadership Breakfast @ 7:30 a.m.**

Speaker: Kathy Cole, MWD Executive Legislative Representative
2016 Legislative Wrap-Up & What We Can Expect in 2017

Tab

5.2



August 31, 2016

Mr. Tom Coleman, General Manager
Rowland Water District
3021 S. Fullerton Road
Rowland Heights, California 91748

JOINT POWERS
INSURANCE AUTHORITY

Re: Training and Risk Assessment Visit

Dear Tom:

P. O. Box 619082
Roseville, CA 95661-9082

phone
916.786.5742
800.231.5742

direct line
916.774.7050
800.535.7899

general fax
916.774.7040

claims fax
916.786.0209

www.acwajpia.com

President

E.G. "Jerry" Gladbach

Vice President

Tom Cuquet

Chief Executive Officer

Walter "Andy" Sells

Executive Committee

Tom Cuquet

David Drake

E.G. "Jerry" Gladbach

David T. Hodgkin

W.D. "Bill" Knutson

Melody A. McDonald

Charles W. Muse

J. Bruce Rupp

Kathleen J. Tieg

Thank you for your personal welcome during my visit to Rowland Water District on August 18, 2016. The purpose was to conduct training, review loss history, and obtain an update on operations. Please extend my thanks to Eric Hall, Senior Water Systems Operator, for scheduling the training my visit and his time during my visit.

Traffic Control and Flagger was provided for your staff and several other ACWA JPIA member agencies. The training focused on the requirements found in the California Manual of Uniform Traffic Control Devices adopted as of November 2014. Those attending reviewed the importance of:

- Using traffic control templates
- Work zone signage and spacing requirements
- Flagger responsibilities and proper hand signals
- Providing safe and reliable direction through all work zones

The material was presented in an interactive format that developed team building and resource sharing. Each attendee was provided with a copy of the 2016 WATCH Book, to be used as a reference when setting up temporary traffic control. Thank you for opening up your boardroom to host this class.

We reviewed the District's loss history. The Experience Modification Rates (E-Mod) in the Workers' Compensation (WC) and Liability Programs are currently better than average (less than 1.0) in both Programs. As a result, the District is receiving premium discounts in excess of \$15,000. In the Property Program there has not been a major loss in the last three policy years. There is no E-Mod associated with the Property Program. Please thank your staff for their continuing efforts in risk management and loss reduction.

Your staff also oversees the financial operations related to the Pomona-Walnut-Rowland Joint Waterline Commission. Walnut Valley Water District continues to be responsible for the inspection and maintenance of the Commission. There was only one reported Liability loss related to these operations since the Commission joined the Program in the 1986/87 policy year. The Commission does not have exposures, and therefore, does not participate in our Property or Workers' Compensation Programs.

Thank you for your continuing support of the "Commitment to Excellence" (C2E) Program. Eric highlighted a number of best practices and C2E actions that are being implemented to reduce exposures. These include:

Mr. Tom Coleman, General Manager
Rowland Water District
August 31, 2016
Page 2

- Adding backup cameras on large fleet vehicles (> 1.5 tons) to increase visibility and reduce backing incidents. (Vehicle Best Practices)
- Installing lightweight manhole lids to reduce the possibility of ergonomic injuries (lifting/back injuries). (Ergonomic Best Practices)
- Upgrading security systems at the main office that includes the addition of panic buttons, automatic door locks, and emergency strobes. (Infrastructure Best Practices)

Please pass on my compliments to your staff for their ongoing C2E efforts to reduce the number of incidents and value of claims.

Changes that have occurred in personnel at the JPIA were discussed. These are related to the retirements of Dick Damon and Diane Salvador. We have two new claims managers: Jennifer Nogosek, Liability and Property Claims Manager; and Melody Tucker, Workers' Compensation Claims Manager. Karen Thesing has also joined us as our Director of Insurance Services. Please feel free to reach out and have your staff introduce themselves.

Cyber Liability Coverage will be added to all Liability Program members at no extra charge for the 2016/17 program year. The Cyber Coverage will protect the members from a variety of cyber exposures. The coverage limit is \$2 million per occurrence, and there is a range of deductibles. Be on the lookout for additional details on this coverage in the near future.

As a reminder, the JPIA wants to be notified of any potential claim. This is especially true in the event of a work related injury, or property/liability damage due to a line break or flooding. Remember that we have two hotlines: Employment Practices and Risk Transfer. Flyers are enclosed for your reference.

We welcome the opportunity to provide insurance coverage and related risk management services for Rowland Water District. Please consider us your partner in risk management. If you have any questions or need additional assistance, please contact me at (760) 224-4322, or pkuchinsky@acwajpia.com.

Sincerely,



Peter Kuchinsky II, CSP, CEAS I, STSC
Lead Risk Management Consultant

831:ll

c: Eric Hall, Senior Water Systems Operator
JPIA Member Services
JPIA Risk Management Committee
Robert W. Lewis, JPIA Board Member (w/o Enc.)